



Installation Instructions

*GuardShield™
Safety Light Curtain
and
GuardShield Remote Teach*

Conditions required for proper use of the GuardShield Safety Light Curtain

Please make sure you read and understand these requirements before you select and install the GuardShield safety light curtain. GuardShield safety light curtains are point of operation safeguarding devices. These safety light curtains are intended to be used to provide point of operation safeguarding of personnel on a variety of machinery.

The GuardShield family of safety light curtains are general purpose presence sensing devices which are designed to protect personnel working on or near machinery.

The installation of the GuardShield safety light curtain must comply with all applicable federal, state and local rules, regulations, and codes.

It is the responsibility of the employer to properly install, operate and maintain the product as well as the machinery on which the GuardShield presence sensing device is installed.

GuardShield safety light curtains must be properly installed by qualified personnel.

GuardShield safety light curtains are presence sensing devices and will not protect personnel from heat, chemicals or flying parts. They are intended to signal a stop of hazardous machine motion when the sensing field is broken.

GuardShield safety light curtains can only be used on machinery which can be stopped anywhere in its stroke or cycle.

GuardShield safety light curtains should never be used on full revolution clutched machinery.

The effectiveness of the GuardShield safety light curtains depend upon the integrity of the machine control circuit. The machinery that the GuardShield presence sensing device is installed should have control circuitry that is fail safe in design.

All stopping mechanisms for the machinery should be inspected regularly to ensure proper operation. The protected machinery must have a consistent reliable and repeatable stopping time.



ATTENTION! Failure to read and follow these instructions can lead to misapplication or misuse of the GuardShield safety light curtains, resulting in personal injury and damage to equipment.

GuardShield Safety Light Curtain Installation Instructions

Table of Contents

GuardShield Safety Light Curtain	2	Safety Instructions—Maintenance	18
Introduction	2	Daily Inspection	18
Safety Precautions	2	Six-month Inspection	19
Principles of Safe Use and Symbols Used	2	Cleaning	19
Specialist Personnel	2	Technical Specifications	20
Range of Uses of the Device	3	Model Overview	21
Proper Use	3	Dimensions	22
General Protective Notes and Protective Measures	3	GuardShield Remote Teach	23
Product Description	3	Introduction	23
Special Features	3	System Delivery	23
Light Curtain Principle of Operation	3	Remote Teach Box—Keyswitch Positions	23
Examples of Range of Use	4	System Installation	23
Safety Functions	4	Remote Teach Procedure	24
Blanking	5	Remote Teach System Catalog Numbers	24
Installation and Mounting	7	Accessories	25
Correct Installation	7	Agency Approvals	
Incorrect Installation	7	CE marked for all applicable directives, cULus, UL 1998	
Response Time	8	UL 61496 Parts 1 & 2	
Determining the Safety Distance	8	IEC 61496 Parts 1 & 2	
US Safety Distance Formula	8	TUV Nord	
OSHA Safety Distance Calculation Formula	8	All specifications subject to change.	
The ANSI Safety Distance Formula	9	<u>IMPORTANT: Save these instructions for use at a future time.</u>	
European Safety Distance Formula	9	Generally recognized technical regulations and quality assurance system ISO 9000 are carefully applied during the development and production of Allen-Bradley/Guardmaster products.	
Multiple GuardShields	10	This technical description must be followed when installing and commissioning the GuardShield. Inspection and commissioning must be carried out by a qualified person.	
Mounting Brackets	11	Rockwell Automation reserves the right to make changes or revisions to the material contained in this publication and cannot be held liable for incidental or consequential damages resulting from the furnishing, performance or use of this material.	
Electrical Installation	11		
Connections	11		
Wiring Diagram	13		
Checklist	18		
Alignment	18		
System Status Indicators	17		
System Configuration	14		
Teach Function	15		
Troubleshooting Guide	16		

To obtain an electronic version of this manual, please visit the web site at www.ab.com/manuals/pd/slightc.htm.

Pour obtenir une version électronique en Français merci de visiter le site www.ab.com/manuals/pd/slightc.htm.

Per ottenere la versione elettronica in Italiano di questo manuale, si prega di visitare: www.ab.com/manuals/pd/slightc.htm.

Um eine deutsche Version dieses elektronischen Handbuchs zu erhalten, besuchen Sie www.ab.com/manuals/pd/slightc.htm.

Para obtener una versión electrónica de este manual en Español, por favor visite www.ab.com/manuals/pd/slightc.htm.

Para obter a versão eletrônica deste manual favor visitar www.ab.com/manuals/pd/slightc.htm.

GuardShield Safety Light Curtain Installation Instructions

GuardShield Safety Light Curtain

Introduction

The GuardShield safety light curtain is a general purpose presence sensing device designed for use on hazardous machinery providing point of operation, as well as, perimeter and access guarding.

It is a self-contained, two box, Type 4 ESPE (Electro Sensitive Protective Equipment) with dip-switch selectable parameters.

Features of the GuardShield, which are integrated into the system's receiver;

- Fixed blanking
- Floating blanking
- External device monitoring (EDM)
- Internal or external restart
- Beam coding

IMPORTANT: These installation instructions are designed to address the technical personnel of the machine manufacturer and or the installer of the safety system regarding the proper mounting, configuration, electrical installation, commissioning, operation and maintenance of the GuardShield safety light curtain.

These installation instructions do not provide instruction for the operation of machinery to which the GuardShield safety light curtain is, or will be, integrated. Only qualified personnel should install this equipment.

Safety Precautions

Principles for Safe Use and Symbols Used

The following instructions are preventive warnings to ensure the safe and proper operation of the GuardShield. These instructions are an essential part of the safety precautions and therefore have to be observed at any time.

Throughout this manual we use the labels **ATTENTION** and **IMPORTANT** to alert you to the following:



ATTENTION!

Failure to observe may result in dangerous operation

ATTENTION: Identifies information about practices of circumstances that can lead to personal injury or death, property damage, or economic loss.

ATTENTION helps you

- Identify a hazard
- Avoid a hazard
- Recognize the consequences

IMPORTANT: Identifies information that is especially important for successful application and understanding of the product.



ATTENTION: Potentially hazardous situation, which, if not prevented, might lead to serious or deadly injury.

Failure to observe may result in dangerous operation.

The GuardShield may be used in safety applications, which in a risk analysis acc. to pr EN 1050 or EN 954-1 have reached category 4.



ATTENTION: The GuardShield must not be used with machines that cannot be stopped electrically in an emergency.

The safety distance between the GuardShield and a dangerous machine movement has to be maintained at all times.

Additional mechanical protective devices have to be installed in a way that hazardous machine elements cannot be reached without passing through the protective field.

The GuardShield has to be installed in a way that operators can only operate within the sensing area.

Improper installation can result in serious injury.

Never connect the outputs to +24V DC. If the outputs are connected to +24V DC, they are in ON-state and cannot stop hazardous spots at the machine/application.

Never expose the GuardShield to flammable or explosive gases.

Regular safety inspections are imperative (see maintenance).

Do not repair or modify the GuardShield. The GuardShield safety light curtain is not field repairable and can only be repaired at the factory. Removal of either of the GuardShield endcaps will void the warranty terms of this product.

Specialist Personnel

The GuardShield safety light curtain must be installed, commissioned and serviced only by a qualified person. A qualified person is defined as a person who:

- Has undergone the appropriate technical training

and

- Who has been instructed by the responsible machine operator in the operation of the machine and the currently valid safety guidelines

and

- Who has read and has ongoing access to these installation instructions

Range of Uses of the Device

The GuardShield safety light curtain is classified as electro-sensitive protective equipment (ESPE). The physical resolution is 14mm (0.55in) or 30mm (1.18in). The maximum protective field width is 7m (22.9ft) for the 14mm (0.55in) resolution and 18m (59ft) for the 30mm (1.18in) resolution GuardShield. The protective field height is between 160mm (6.3in) and 1760mm (69.2in).

The device is a *Type 4 ESPE* as defined by IEC 61496-1 and -2 and is therefore allowed for use with controls in safety category Type 4 in compliance with EN 954. The device is suitable for:

- Point of operation protection (finger and hand protection)
- Hazardous area protection
- Access protection

Access to the hazardous point must be allowed only through the protective field. The machine/system is not allowed to start as long as personnel are within the hazardous area. Refer to the “Examples of Range of Use” on page 4 for an illustration of the protection modes.

Depending on the application, mechanical protection devices may be required in addition to the safety light curtain.

Proper Use

The GuardShield safety light curtain must be used only as defined in the “Range of Uses of the Device.” It must be used only by qualified personnel and only on the machine where it has been installed and initialized by qualified personnel.

If the device is used for any other purposes or modified in any way, warranty claims against Allen-Bradley/Guardmaster shall become null and void.

General Protective Notes and Protective Measures

IMPORTANT: Safety Notes

Please observe the following items in order to ensure the proper and safe use of the GuardShield safety light curtain.

- The national/international rules and regulations apply to the installation, use and periodic technical inspections of the safety light curtain, in particular:
 - ◆ Machine Directive 98/37/EEC
 - ◆ Equipment Usage Directive 89/655/EEC
 - ◆ The work safety regulations/safety rules
 - ◆ Other relevant health and safety regulations

Manufacturers and users of the machine with which the safety light curtain is used are responsible for obtaining and observing all applicable safety regulations and rules.

- The notices, in particular the test regulations of these installation instructions (e.g. on use, mounting, installation or integration into the existing machine controller) must be observed.
- The tests must be carried out by specialist personnel or specially qualified and authorized personnel and must be recorded and documented to ensure that the tests can be reconstructed and retraced at any time.
- The installation instructions must be made available to the user of the machine where the GuardShield safety light curtain is installed. The machine operator is to be instructed in the use of the device by specialist personnel and must be instructed to read the installation instructions.

Product Description

This section provides information on the special features and properties of the safety light curtain. It describes the structure and functions of the unit, in particular the different operating modes.

- Please read this section before mounting, installing and commissioning the unit.

Special Features

- Start interlock
- Restart interlock
- Teachable fixed blanking
- One or two beam floating blanking
- External Device Monitoring (EDM)
- Machine test signal
- Beam coding

Light Curtain Principle of Operation

The GuardShield safety light curtain consists of a nonmatched pair of optic units i.e., transmitter and receiver. The transmitter emits infrared light, which is received and processed by the GuardShield's receiver. The distance between the transmitter and receiver is referred to as the protective field width or range. The protective field height is the distance between the system's first beam and last beam. Synchronization of the transmitter and receiver is accomplished optically. There is no electrical connection between the transmitter and receiver.

GuardShield Safety Light Curtain Installation Instructions

The Light Curtain Principle

The GuardShield safety light curtain consists of a transmitter and a receiver.

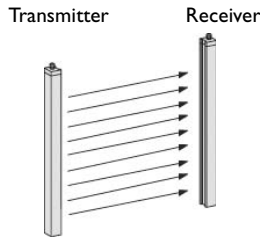

Figure 1: Components of the GuardShield

The upper and lower limit of the protective field is shown by markings on the housings.

The width of the protective field is derived from the length of the light path between sender and receiver and must not exceed the maximum rated width of the protective field (7m-14mm (22.9ft-0.55in), 18m-30mm (59.0ft-1.18in)).

Examples of Range of Use

The GuardShield safety light curtain operates as a proper protective device only if the following conditions are met:

- The control of the machine must be electrical.
- The controlled machine must be able to be stopped anywhere in the machine's stroke or cycle.
- The transmitter and receiver must be mounted such that access to the hazard is only through the light curtain's protective field.
- The restart button must be located outside the hazardous area such that it cannot be operated by a person working inside the hazardous area.
- The statutory and local rules and regulations must be observed when installing and using the device.

Safety Functions

The GuardShield safety light curtain offers a variety of functions, which are integral to the system.

Operating modes, functions and features of the GuardShield system are activated through dip switch settings.

IMPORTANT: The protective system must be tested for proper operation after each and every change to the configuration.

Guard Only

When in the guard only mode of operation, the light curtain operates as an on/off device, meaning the OSSD outputs switch off/on according to an obstruction or clearing of the detection field.

Start Interlock

The start interlock prevents the OSSD outputs from switching to ON state after power up of the system with the protective field unobstructed. A manual reset of the system is required for the GuardShield to enter the ON state.

This can be accomplished by one of two methods.

- Actuation of a momentary N.O. push button
- Interruption and restoration of the protective field within 1 second.

Activation of this mode of operation and selection of the resetting method is through dip-switch settings. Indication of this mode of operation is through illumination of a Yellow LED on the GuardShield's receiver.

Restart Interlock

The restart interlock mode of operation prevents the OSSD outputs from switching to ON after interruption and clearance of the protective field. A manual reset of the GuardShield system is required. Resetting of the system is accomplished through a momentary N.O. push button or key switch. Configuration and activation of this mode of operation is through dip-switch settings. The Restart Interlock mode is indicated by the illumination of a Yellow LED on the GuardShield's receiver.

Relay Monitoring (MPCE/EDM)

The relay monitoring function is an input signal to the GuardShield's receiver and is used to monitor the state of the protected machinery's primary control contactors or other final switching device. Detection of unsafe conditions such as welded contacts, cause the GuardShield to enter a lockout condition (OSSD's OFF). Activation of this mode of operation is through dip-switch setting in the GuardShield's receiver.

System Testing

The GuardShield performs a complete system self-test at power up and switches to the ON state if the system is properly aligned and the protective field is unobstructed and the start/restart interlock modes of operation are deactivated.

External Test (Machine Test Signal)

A test cycle of the system can be triggered by an external test signal to the GuardShield's transmitter. Supplying or removing a signal (+24V DC) via a N.C. or N.O. switch at the test input deactivates the transmitter for the duration of the test signal, simulating an interruption of the protective sensing field. The test input must be configured via a dip-switch located in the GuardShield transmitter.

Beam Coding

If several safety light curtains are operating in close proximity to one another, it is possible that the transmitter's infrared light from one GuardShield system is "seen" by another GuardShield system's

GuardShield Safety Light Curtain Installation Instructions

receiver. This would cause a “nuisance” stop. To prevent this optical interference, the GuardShield has the ability to have the transmitter generate different beam patterns, which is referred to as “Beam coding.” Selection and activation of beam coding is accomplished through dip-switch settings in both the transmitter and receiver.

The following settings are available in the GuardShield safety light curtain; noncoded and coded.

IMPORTANT: Beam coding improves resistance to optical interference.

Beam coding increases the system’s response time, which may also increase the required safety distance. Refer to Safety Distance calculations on page 8 of this manual.

Blanking

The GuardShield safety light curtain is capable of fixed blanking of one or more adjacent beams, exclusive of the synchronization beam. Floating blanking of one or two beams is also capable of being configured. It is possible to activate both fixed and floating blanking simultaneously.

Fixed Blanking

The fixed blanking mode of operation is activated through dip-switch settings located in the GuardShield’s receiver. The beams to be blanked are “taught” by depressing the teach button located in the GuardShield’s receiver endcap while the object is in the GuardShield’s sensing field.

The fixed blanking mode of operation is monitored. If any part or all of the object is removed from the sensing field, the GuardShield’s OSSD outputs go to the OFF state.

The GuardShield fixed blanking mode of operation will not be activated until the teach function is complete and the access door is closed.

IMPORTANT: The configuration and activation of fixed blanking creates a “hole” in the GuardShield’s protective field. If the fixed object that is located in the protective field does not completely fill the area between the GuardShield’s transmitter and receiver it is necessary to obstruct access to the hazard by additional means. This is usually accomplished by “hard guarding” the open area.

Note: “Hard guards” refer to mechanical barriers.

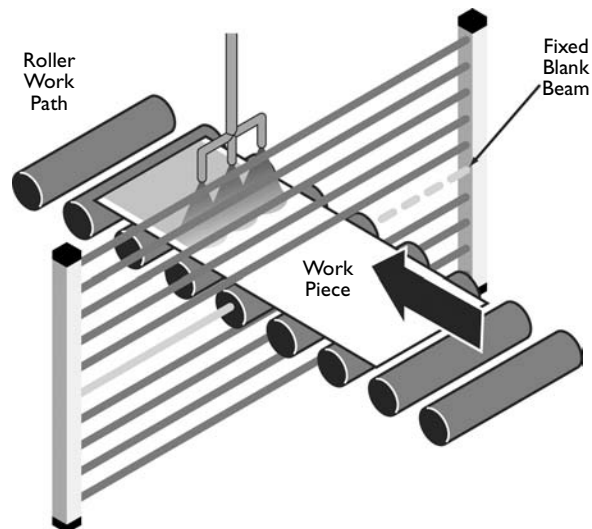

Figure 2: Monitored fixed blanking of in-feed rollers

- Beams are “taught” to ignore the fixed object in the sensing field
- The fixture or object must remain in the sensing field or GuardShield enters a Fault state

Fixed Blanking enables the blanking out of fixed objects in the sensing area of the light curtain. The following table shows the reaction of the monitored machine with Fixed Blanking deactivated and activated.

IR Beam	Fixed Blanking Deactivated		Fixed Blanking Activated		
	On	Stop	On	Stop	Stop
1	○	○	○	⊗	○
2	○	○	⊗	⊗	⊗
3	○	⊗	⊗	⊗	□
4	○	○	⊗	⊗	⊗
5...	○	○	○	○	○
Machine	On	Stop	On	Stop	Stop

GuardShield Safety Light Curtain Installation Instructions

Description of the symbols

Symbol	Description
○	Beam not interrupted
⊗	Beam interrupted
□	Beam is activated for Fixed Blanking and not interrupted
⊗	Beam is activated for Fixed Blanking and interrupted

Floating Blanking

The floating blanking mode of operation is activated through dip-switch settings located in the GuardShield's receiver. Floating blanking allows one or two beams located anywhere in the protective field to be "blanked out" i.e. blocked beam(s) ignored and GuardShield remains with outputs active.

The following chart depicts the Machine state for 1 and 2 beam floating blanking.

With Floating Blanking up to two light channels can be interrupted.

Note: It is not possible to activate more than one beam floating blanking on a 30mm resolution GuardShield system.

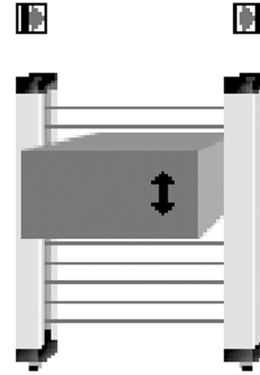

Figure 3: Floating blanking

Floating Blanking allows an object to "float" in (move within, or in and out of) the GuardShield's protective field without causing the light curtain's outputs to change to the OFF state.

IMPORTANT: Actuation of the floating blanking mode of operation changes the resolution of the GuardShield.

GuardShield Resolution	Number of Beams "Floated"	Effective Resolution
14mm (0.55in)	1 Beam	24mm (0.94in)
	2 Beam	34mm (1.34in)
30mm (1.18in)	1 Beam	50mm (1.97in)

IR Beam	Floating Blanking Deactivated	Floating Blanking 1 Channel Active				Floating Blanking 2 Channels Active							
		1	2	3	4	1	2	3	4	5	6	7	
1	○	○	○	○	○	○	○	○	○	○	○	○	⊗
2	○	○	○	⊗	⊗	○	○	⊗	⊗	⊗	⊗	⊗	○
3	⊗	○	⊗	⊗	○	○	⊗	⊗	○	⊗	○	⊗	⊗
4	○	○	○	○	⊗	○	○	○	⊗	⊗	⊗	⊗	○
5	○	○	○	○	○	○	○	○	○	○	○	⊗	⊗
Machine	Stop	On	On	Stop	Stop	On	On	On	On	On	On	Stop	Stop

Installation and Mounting

This section describes the preparation, selection and installation of the GuardShield safety light curtain.

The GuardShield safety light curtain is suitable for most operating environments (IP65 environmental rating). Proper safety distance as well as adequate protective height must be observed.

IMPORTANT: The installation of the GuardShield safety light curtain must adhere to the ANSI standard B11.19/E4.2.3.3.6, which requires that a presence sensing device shall prevent the operator or others from reasonably reaching over, around, or under the sensing field into the hazardous area. Auxiliary safeguarding may be required in conjunction with the GuardShield to meet this requirement.

Determine if the machinery, on which the GuardShield is to be mounted, meets the requirements as specified in the beginning of this manual, i.e., machinery must be able to be stopped anywhere in its stroke or cycle, consistently and repeatedly.

Correct Installation

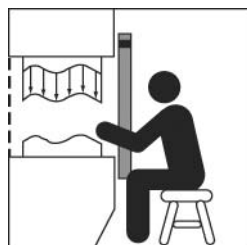

Operators cannot reach hazardous machine parts without passing through the protective field.

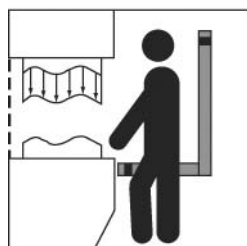

Operators must not step between protective field and hazardous machine parts (by-pass prevention).

Incorrect Installation

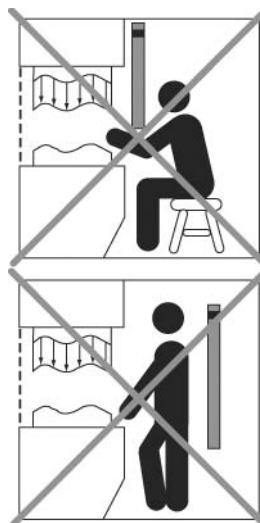

Operators can reach hazardous machine parts without passing through the protective field.

Operators can step between protective field and hazardous machine parts.

The GuardShield must be mounted at the proper distance from the point of operation hazard. This distance is referred to as the Safety Distance.

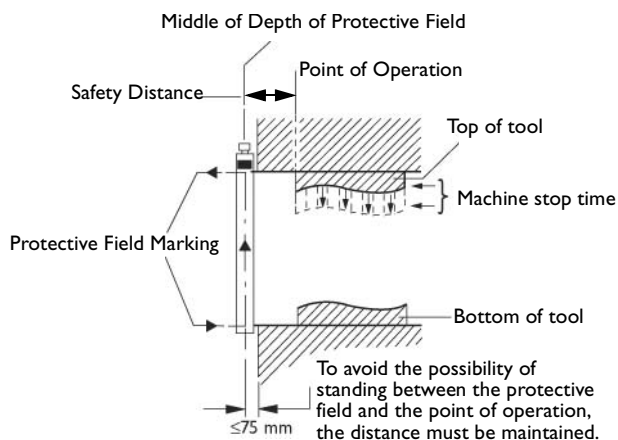

Figure 4: Determining machine stopping time and safety distance

GuardShield Safety Light Curtain Installation Instructions

Response Time

The response time of the GuardShield safety light curtain depends on the height of the protective field, the resolution and the number of light beams as well as the coding of the system.

Resolution—mm (in)	Protective Height—mm (in)	Number of Beams	Response Time w/o Coding	Response Time w/ Coding
14 (0.55)	160 (6.3)	16	20ms	30ms
14 (0.55)	320 (12.5)	32	20ms	30ms
14 (0.55)	480 (18.8)	48	20ms	30ms
14 (0.55)	640 (25.1)	64	20ms	30ms
14 (0.55)	800 (31.4)	80	20ms	30ms
14 (0.55)	960 (37.7)	96	20ms	30ms
14 (0.55)	1120 (44.0)	112	20ms	30ms
14 (0.55)	1280 (50.3)	128	20ms	30ms
14 (0.55)	1440 (56.6)	144	20ms	30ms
14 (0.55)	1600 (62.9)	160	25ms	35ms
14 (0.55)	1760 (69.2)	176	25ms	35ms

Resolution	Protective Height	Number of Beams	Response Time w/o Coding	Response Time w/ Coding
30 (1.18)	160 (6.3)	8	20ms	30ms
30 (1.18)	320 (12.5)	16	20ms	30ms
30 (1.18)	480 (18.8)	24	20ms	30ms
30 (1.18)	640 (25.1)	32	20ms	30ms
30 (1.18)	800 (31.4)	40	20ms	30ms
30 (1.18)	960 (37.7)	48	20ms	30ms
30 (1.18)	1120 (44.0)	56	20ms	30ms
30 (1.18)	1280 (50.3)	64	20ms	30ms
30 (1.18)	1440 (56.6)	72	20ms	30ms
30 (1.18)	1600 (62.9)	80	20ms	30ms
30 (1.18)	1760 (69.2)	88	20ms	30ms

IMPORTANT: Determining Stop Time: The measurement of stopping time (Ts) must include the stopping times of all devices in the stop circuit. Not including all device and control system elements when calculating Ts will result in an inaccurate safety distance calculation.

Determining the Safety Distance

The light curtain must be mounted with proper safety distance

- From the point of danger
- From reflecting surfaces

US Safety Distance Formula



ATTENTION: The GuardShield safety light curtains must be mounted at a sufficient distance from the pinch point or point of operation hazard to ensure that the machine stops before a person's finger, hand, arm(s), or body reaches the hazard.

This distance, referred to as the safety distance, must be properly calculated prior to determining the safety light curtain protective height and mounting the light curtains on the machine. Failure to properly calculate this safety distance may result in operator injury.

IMPORTANT: Regardless of the calculated safety distance, GuardShield safety light curtains should never be mounted closer than six inches from the point of operation or pinch point hazard.

In the United States there are two formulas that are used to properly calculate the safety distance. The first, the OSHA formula, is the minimum requirement for the calculation of the safety distance. The second formula, the one recommended by Rockwell Automation, is the ANSI formula, which incorporates additional factors to be considered when calculating the safety distance.

OSHA Safety Distance Calculation Formula

The OSHA safety distance formula as specified in CFR Subpart O 1910.217 is as follows:

$$Ds = 63 \times Ts$$

- Ds Safety Distance
- 63 Is the OSHA recommended hand speed constant in inches per second
- Ts Is the total stop time of all devices in the safety circuit, measured in seconds. This value must include all components involved in stopping the hazardous motion of the machinery. For a mechanical power press it is the stopping time measured at approximately the 90° position of the crankshaft rotation.

Note: The Ts number must include the response times of all devices, including the response time of the safety light curtain, the safety light curtain controller (if used), the machine's control circuit and any other devices that react to stop the hazardous motion of the machinery. Not including the response time of a device or devices in the stop time calculation will result in insufficient safety distance for the application. This may result in operator injury.

The ANSI Safety Distance Formula

The ANSI safety distance formula, which is the Rockwell Automation recommended formula, is as follows:

$$D_s = K \times (T_s + T_c + T_r + T_{bm}) + D_{pf}$$

- D_s** Minimum safety distance between the safe guarding device and the nearest point of operation hazard, in inches.
 - K** Hand speed constant in inches per second. The ANSI standard value is 63 inches per second when the operator begins reaching toward the point of operation hazard from rest. NOTE: ANSI B11.19 1990 E4.2.3.3.5 states "The value of the hand speed constant, K, has been determined by various studies and although these studies indicate speeds of 63 inches/second to over 100 inches/second, they are not conclusive determinations. The employer should consider all factors, including the physical ability of the operator, when determining the value of K to be used."
 - T_s** Stop time of the machine tool measured at the final control element.
 - T_c** Response time of the control system
- Note:** T_s and T_c are usually measured by a stop time measuring device.
- T_r** Response time of the presence sensing device (safety light curtain) and its interface, if any. This value is generally stated by the device manufacturer or it can be measured by the user.
 - T_{bm}** Additional time allowed for the brake monitor to compensate for variations in normal stopping time.
 - D_{pf}** Depth penetration factor. It is an added distance to allow for how far into the protective field an object, such as a finger or hand, can travel before being detected. D_{pf} is related to the safety light curtain's object sensitivity. Object sensitivity is the smallest diameter object which will always be detected anywhere in the sensing field.

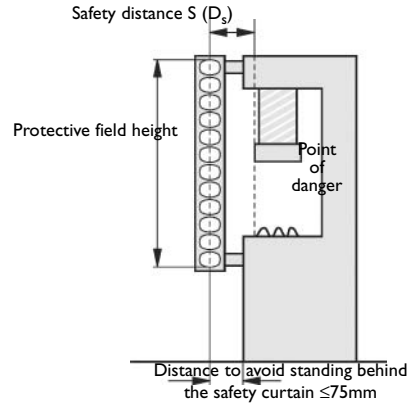

Figure 5: Safety distance from the point of danger

How to Calculate the Safety Distance S According to EN 999 and EN 294:

- First, calculate S using the following formula:
 $S = 2000 \times T + 8 \times (d - 14) \text{ [mm]}$

Where ...

T = stopping/run-down time of the machine
 + response time of the protective device [s]

d = resolution of the light curtain [mm]

S = safety distance [mm]

The reach/approach speed is already included in the formula.

- If the result S is ≤ 500mm (19.6in), then use the determined value as the safety distance.
- If the result S is > 500mm (19.6in), then recalculate S as follows:
 $S = 1600 \times T + 8 \times (d - 14) \text{ [mm]}$
- If the new value S is > 500mm (19.6in), then use the newly determined value as the minimum safety distance.
- If the new value S is ≤ 500mm (19.6in), then use 500mm (19.6in) as the safety distance.

Example:

Stopping/run-down time of the machine = 290ms
 Response time = 30ms
 Resolution of the light curtain = 14mm (0.55in)
 $T = 290\text{ms} + 30\text{ms} = 320\text{ms} = 0.32\text{s}$
 $S = 2000 \times 0.32 + 8 \times (14 - 14) = 640\text{mm} (25.1\text{in})$
 $S > 500\text{mm}$, therefore:
 $S = 1600 \times 0.32 + 8 \times (14 - 14) = \underline{\underline{512\text{mm} (20.1\text{in})}}$

Example:

In opto-electronic safeguarding, such as with a perpendicular safety light curtain applications with object sensitivity (effective resolution) less than 2.5 inches, the D_{pf} can be approximated based on the following formula:

$$D_{pf} \text{ (inches)} = 3.4 \times (\text{Object Sensitivity} - 0.276),$$

but not less than 0.

European Safety Distance Formula

A safety distance must be maintained between the light curtain and the point of danger. This safety distance ensures that the point of danger can only be reached after the dangerous state of the machine has been completely removed.

The safety distance as defined in EN 999 and EN 294 depends on:

- Stopping/run-down time of the machine or system. (The stopping/run-down time is shown in the machine documentation or must be determined by taking a measurement.)
- Response time of the protective device, e.g. GuardShield (for "Response Time" see page 8).
- Reach or approach speed.
- Resolution of the light curtain and/or beam separation.

GuardShield Safety Light Curtain Installation Instructions

Minimum Distance from Reflecting Surfaces

The infrared light from the sender may be reflected off of shiny surfaces and be received by the system's receiver. If this condition occurs, it can result in an object not being detected when it enters the GuardShield's sensing field.

All reflecting surfaces and objects (e.g. material bins) must therefore be located at a minimum distance *a* from the protective field of the system. The minimum distance *a* depends on the distance *D* between sender and receiver.

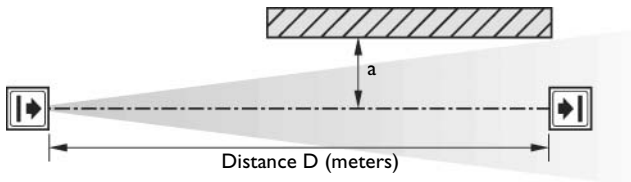

Figure 6: Minimum distance from reflecting surfaces

How to Determine the Minimum Distance from the Reflecting Surfaces:

- Determine the distance *D* [m] sender-receiver
- Read the minimum distance *a* [mm] from the graph:

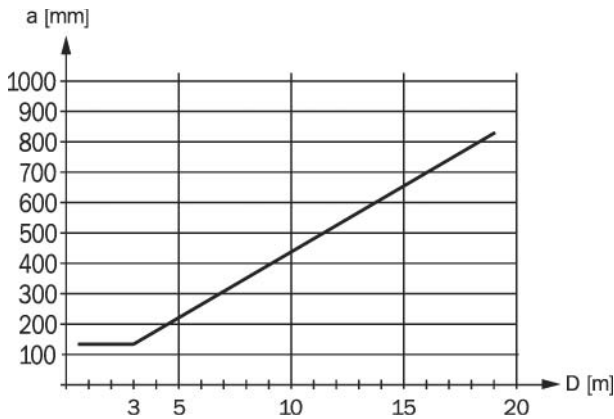

Figure 7: Graph, minimum distance from reflecting surfaces

The effective aperture angle for the GuardShield system is +/- 2.5° at a mounting distance of > 3.0m (9.8ft). Calculate the minimum distance to reflecting surfaces depending on the distance between the transmitter and the receiver, using an aperture angle of +/- 2.5°, or take the appropriate value from the following table:

Distance Between Transmitter and Receiver (Range L)—m (ft)	Minimum Distance a—mm (in)
0.2 to 3.0 (0.65 to 9.8)	135 (5.31)
4.0 (13.1)	175 (6.88)
5.0 (16.4)	220 (8.66)
6.0 (19.6)	265 (10.43)
7.0 (22.9)	310 (12.2)
10.0 (32.8)	440 (17.32)
16.0 (52.4)	700 (27.55)

Note: formula: $a = \tan 2.5^\circ \times D$ [mm]

a = minimum distance to reflecting surfaces
D = distance between transmitter and receiver

Multiple GuardShields

When two or more GuardShields are mounted in close proximity to one another, it may be possible for the receiver of one GuardShield pair to receive infrared light from the transmitter of another GuardShield pair. This optical interference can be overcome by the GuardShield feature of Beam Coding. Beam coding changes the pulse pattern of infrared light emitted by a GuardShield transmitter.

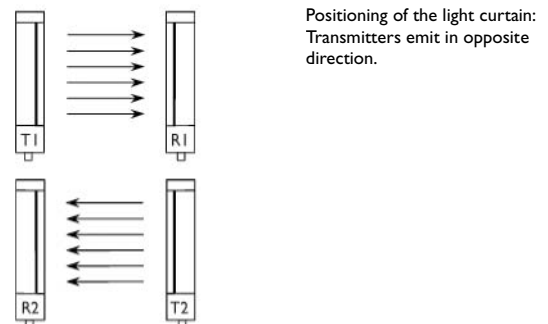
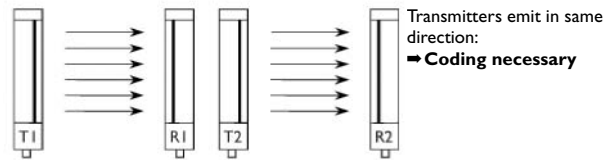
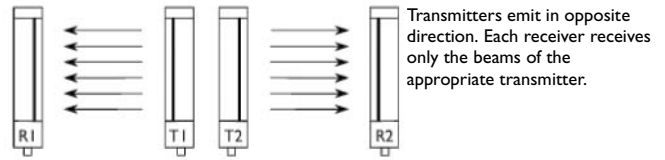
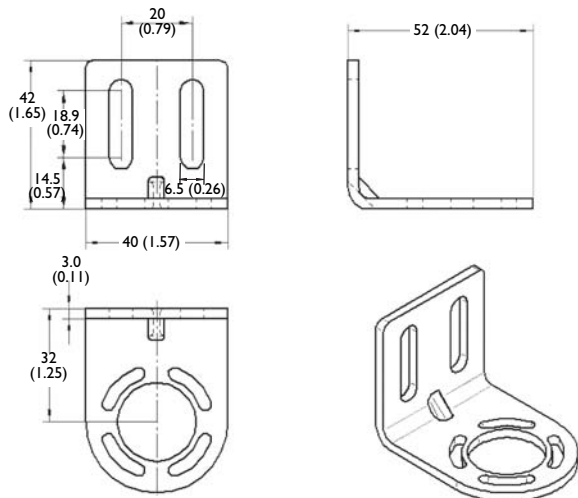

Figure 8: Multiple GuardShield alignment options

Mounting Brackets

The GuardShield is mounted using right angle brackets attached to the endcaps of both transmitter and receiver. It may be necessary to use additional brackets to mount the GuardShield at a proper safety distance from the machinery hazard



Optional Middle Mounting Bracket (440L-AF6108)

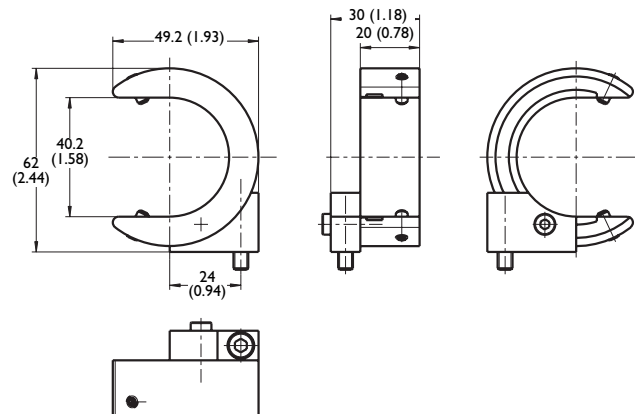

Note: Should be used in vibration applications for protective heights of 1120mm and larger.

GuardShield Remote Teach Receiver Bracket

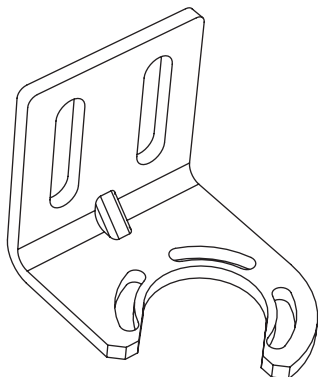

Electrical Installation

Connections

Power Supply

The external voltage supply (+24V DC) must meet the requirements of IEC 61496-1. In addition, the following requirements have to be fulfilled:

- A short-term power failure of 20ms must be bridged by the power supply.
- The power supply has double insulation between the primary and the secondary side.
- The power supply is protected against overload.
- The power supply corresponds to the guidelines of the EWG (industrial environment).
- The power supply corresponds to the Low Voltage Directives.
- The grounded conductor of the power supply device must be connected to a grounded conductor PE.
- The maximum deviation of the voltage levels is 24V DC +/- 20%.

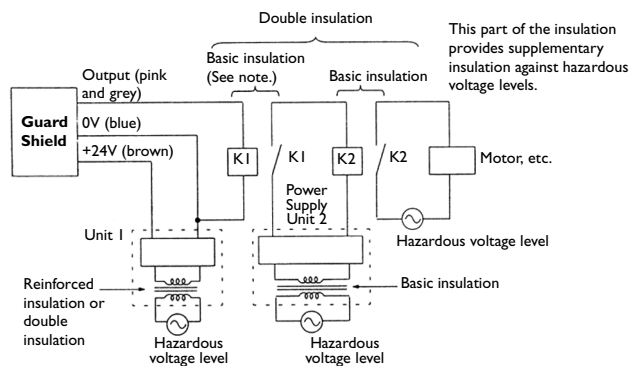

EDM Connection

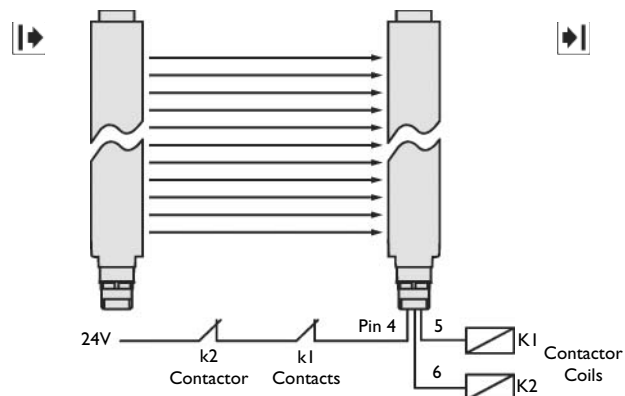
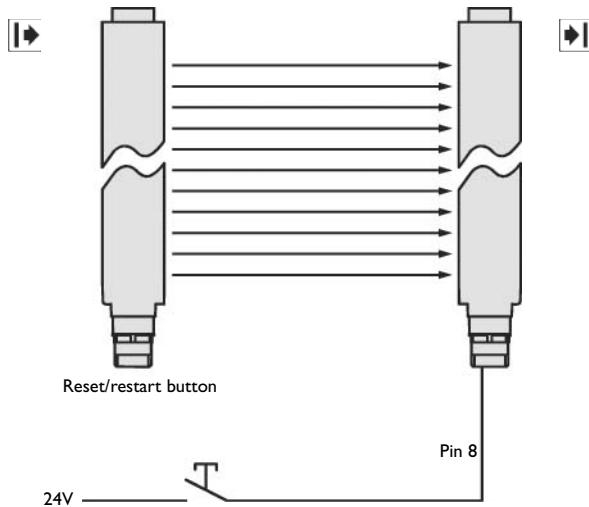

Figure 9: Connecting the contact elements to the EDM

GuardShield Safety Light Curtain Installation Instructions



angle 4-pin and 8-pin DC micro connectors are also offered with the same cable lengths as the straight connectors.

Figure 10: Connecting the reset button/restart button

Connections—mm (in)

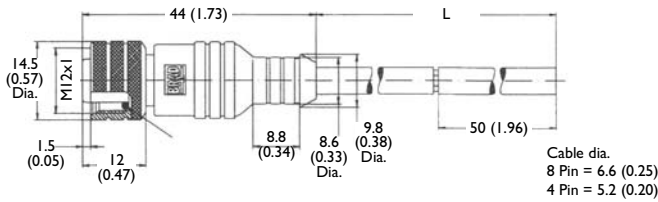

Top View	Color	Pin No.	Signal
			Receiver
	White	1	Auxiliary Output
	Brown	2	+24V DC
	Green	3	Ground
	Yellow	4	EDM
	Gray	5	OSSD 1
	Pink	6	OSSD 2
	Blue	7	0V DC
	Red	8	Start/Restart
Top View	Color	Pin No.	Signal
			Transmitter
	Brown	1	+24V DC
	White	2	No Connection
	Blue	3	0V DC
	Black	4	Machine Test Signal

Cables/Connectors

The GuardShield transmitter connector is a 4-pin DC micro connector offered in cable lengths from 2 meters to 30 meters. The GuardShield receiver connector is an 8-pin DC micro connector offered in cable lengths of 2 meters to 30 meters. Right

Typical Wiring Diagram—Direct to Contactors

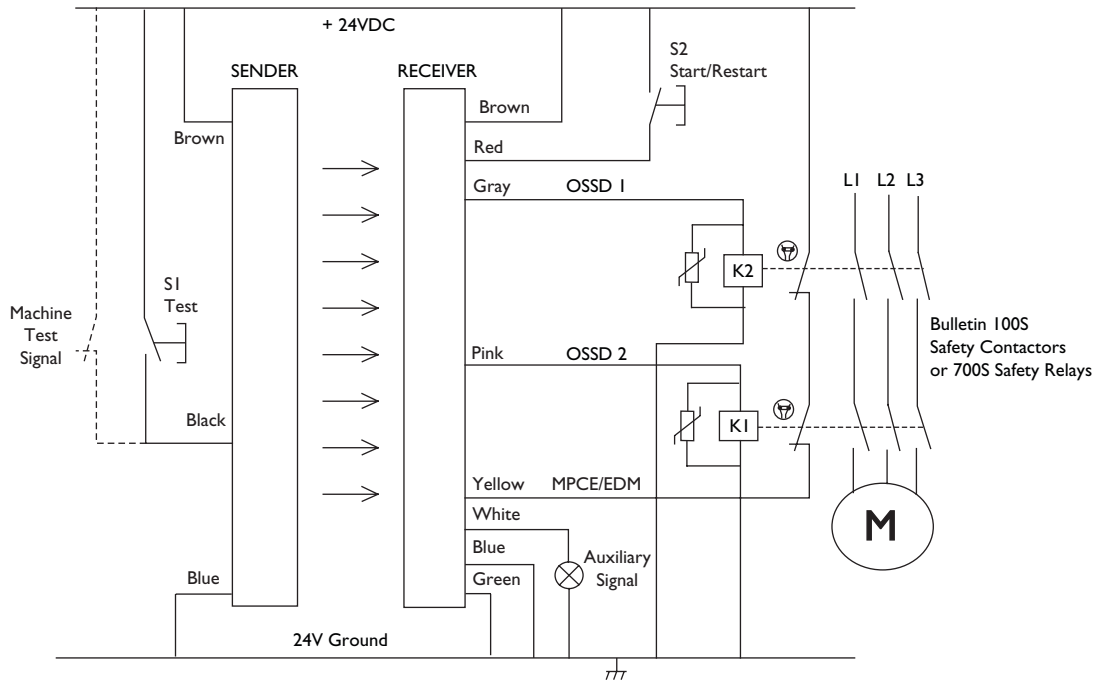

❶ Nonsafety auxiliary output can be connected to a lamp, motor or status to a PLC.

Note: If MPCE/EDM is activated in the GuardShield, the application requires a safety contactor. If MPCE/EDM is not used K1 & K2 can be standard contactors.

GuardShield Safety Light Curtain Installation Instructions

Typical Wiring Diagram—To MSR127 Safety Relay Module

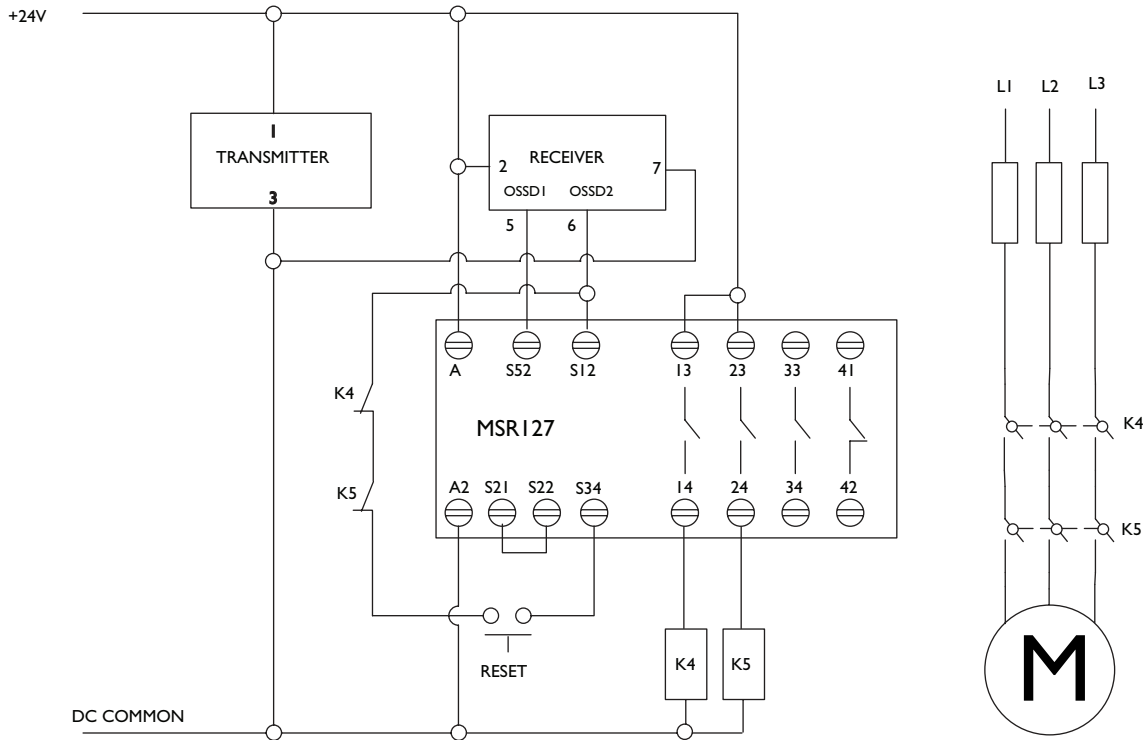

System Configuration

DIP-Switch Selection Settings—Transmitter

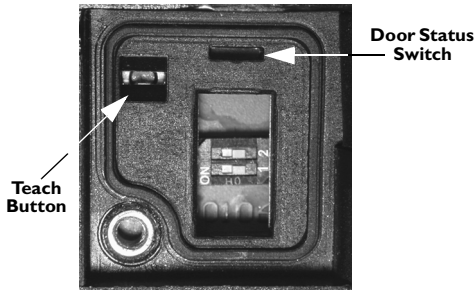

DIP-Switch Selection Settings—Receiver

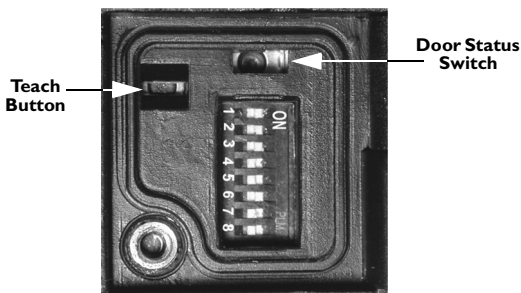

To begin system configuration, use the security tool provided to loosen the screw in the configuration door.

Note: The configuration door screw is a captive screw.

Note: The transmitter can only be configured for beam coding and Machine Test Signal. If neither of these configurations are required, then it is only necessary to configure the GuardShield's receiver.

Identify and set the appropriate dip-switches for the configuration desired.

Dip-switch identification and function is explained in the tables below.

Follow the Teach Function Procedure to reconfigure the GuardShield.

IMPORTANT: After each reconfiguration of the GuardShield, test the system for proper configuration and operation before placing the guarded machine in operation.

After mounting, electrically connecting and aligning the GuardShield safety light curtain, it is now possible to configure your system.

GuardShield Safety Light Curtain Installation Instructions

When delivered from the factory, the following settings are configured.

Receiver—Factory Settings

Switch	Switch Function	Default Setting	Description
1	Mode Activation— Combination activates one of the following modes: Guard only, Start interlock, Restart Interlock	ON	Guard Only
2		ON	
3	MPCE Monitoring disable	ON	Disabled
4	Fixed Blanking Activate	OFF	Disabled
5	Floating Blanking Activate— Single Beam	OFF	Switches 5&6 cannot be activated “On” at the same time.
6	Floating Blanking Activate— Two Beams	OFF	
7	Set Beam Coding	OFF	Disabled
8	Not used	OFF	

Transmitter—Factory Settings

Switch	Switch Function	Default Setting	Description
1	Set Beam Coding	OFF	Disabled
2	Machine Test Signal	OFF	OFF: Signal High active—No connection or connect normally open ON: Signal Low active—Connect N/C

Settings for Mode of Operation—Receiver

Switch 1	Switch 2	Condition	Operation
ON	ON	Guard Only	ON/OFF Operation
OFF	ON	Start Interlock (Push Button Reset)	Interlock at start up—Reset by actuation of pushbutton switch
OFF	OFF	Restart Interlock	Interlock at interruption of sensing area— Reset by actuation of pushbutton switch
ON	OFF	Start Interlock	Interlock at start up—Reset by Interruption/restoration of sensing area for <1 sec



ATTENTION: Every modification at the DIP switches must be stored in the memory of the device through the Teach function.

Teach Function

Procedure:

Step 1 Open cover of the end cap (LED blinks: Receiver is red LED, Transmitter is amber LED).

Step 2 Select the desired switch setting.

Step 3 Press and hold the Teach button. The yellow LED flashes at 10 Hz (10x per second).



Step 4 The yellow LED will stop blinking while the button is depressed. After the yellow stops flashing, release the teach button within 2 seconds.

- After 3 flashes of the yellow LED the function is activated.

Step 5 Close and secure the cover.

Note: The doors on the transmitter and receiver must be closed for the GuardShield to operate.

IMPORTANT: If the GuardShield teach procedure is not properly completed, the unit will remain in the previous operating mode.

IMPORTANT: Once the teach function is completed and the door secured, verify that the operating mode has changed to the intended mode.

GuardShield Safety Light Curtain Installation Instructions

Troubleshooting Guide

The light curtain carries out an internal self-test after startup. If an error occurs, an appropriate signal combination is sent through the LEDs to the transmitter and receiver.

Condition No.	Error Description	Action
8	Internal fault, receiver	<ul style="list-style-type: none">• Check configuration of transmitter and receiver• Replace receiver
9	Internal fault, transmitter	<ul style="list-style-type: none">• Check configuration of transmitter and receiver• Check protective field transmitter/receiver• Check connections transmitter/receiver• Exchange transmitter
10	External fault	<ul style="list-style-type: none">• Check connections of OSSD outputs for short circuit against +24V DC and GND (cable, connected devices)• Exchange receiver
11	External fault (MPCE error) The function Relay monitoring is activated and after clearing the OSSD the input Relay monitoring does not recognize a change of state.	<ul style="list-style-type: none">• Check connection Relay monitoring• Check connected relay for closed contact (if OSSD ON—input Relay monitoring must have GND level, if OSSD OFF—input Relay monitoring must have +24V)• Switch on only after POWER OFF/ON
12	Configuration mode (Receiver)	<ul style="list-style-type: none">• Cover for DIP switch setting at the receiver is open
13	Configuration mode (Transmitter)	<ul style="list-style-type: none">• Cover for DIP switch setting at transmitter is open

GuardShield Safety Light Curtain Installation Instructions

System Status Indicators

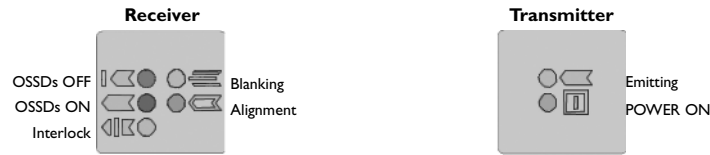

Condition No.	Receiver LEDs					Transmitter LEDs	
	OSSDs OFF Red	OSSDs ON Green	Blanking Yellow	Alignment Amber	Interlock Yellow	Power On Amber	Emitting Yellow
1	OFF	ON	OFF	OFF	OFF	ON	ON
2	ON	OFF	OFF	OFF	OFF	ON	ON
3	ON	OFF	OFF	ON	OFF	ON	ON
4	ON	OFF	OFF	OFF	ON	ON	ON
5	OFF	ON	ON	OFF	OFF	ON	ON
6	OFF	ON	FLASH	OFF	OFF	ON	ON
7	ON	OFF	OFF	OFF	OFF	ON	OFF
8	FLASH	OFF	OFF	OFF	OFF	ON	ON
9	ON	OFF	OFF	OFF	OFF	FLASH	ON
10	FLASH	OFF	OFF	ON	OFF	ON	ON
11	FLASH	OFF	OFF	OFF	ON	ON	ON
12	FLASH	OFF	DATA TRANS	OFF	OFF	ON	ON
13	ON	OFF	OFF	OFF	OFF	FLASH	DATA TRANS

8 through 13 = Fault conditions

Flash rate is approximately 2 Hz (2 times per second)

Condition No.	Description
1	Guard only mode, light curtain unobstructed (aligned, not in interlock)
2	Guard only mode, light curtain interrupted (aligned, not in interlock)
3	Guard only mode, misaligned (not in interlock)
4	Guard only mode, in start or restart interlock (aligned)
5	Fixed blanking mode (aligned, not in interlock)
6	Floating or Floating/Fixed Blanking mode (aligned, not in interlock)
7	Transmitter test input active (pin 4)
8	Internal fault, receiver
9	Internal fault, transmitter
10	External fault (OSSD short to ground, +V, or cross connection)
11	External fault (MPCE/EDM error)
12	Configuration mode (receiver access door open)
13	Configuration mode (transmitter access door open)

Note: For fault conditions 8 through 13, see Troubleshooting guide on page 16.

GuardShield Safety Light Curtain Installation Instructions



ATTENTION: Assure that all power to the machine, and safety system is disconnected during electrical installation.

IMPORTANT: Prior to powering up the GuardShield system, the responsible person should review the following Checklist.

Checklist

Before the initiation of the GuardShield the responsible person should work through the following checklist.

Cable check prior to initiation:

- The power supply is solely connected to the GuardShield.
- The power supply is a 24V DC device, that must comply to all applicable standards of the Machinery Directive 98/37/EC, and the product standard (IEC 61496).
- Proper polarity of the power supply at the GuardShield.
- The transmitter connection cable is properly connected to the transmitter, the receiver connection cable is properly connected to the receiver.
- The double insulation between the light curtain output and an external potential is ensured.
- The OSSD outputs are not connected to +24V DC.
- The connected switching elements (load) are not connected to 24V DC.
- No connection to a conventional power supply.
- If two or more GuardShield are to be used, make sure that each system is properly installed, in order to avoid optical interference.

Switch the GuardShield on and check its function by observing the following:

- 2 seconds after switching on, the system starts to work properly, if the protective field is free of obstructions.

Alignment

The GuardShield has an alignment indicator LED on the receiver.

The amber LED is illuminated when the GuardShield is out of alignment and will turn off when optimal alignment is achieved.

Alignment Procedure:

Mount and connect both transmitter and receiver. They must be parallel to each other and be positioned at the same height.

Turn on power to GuardShield system.

Rotate the Transmitter while watching the amber LED on the receiver to find the point where the indicator for the ON state (Green LED) illuminates and the amber LED goes off.

Determine the maximum left and right turning angles and position unit in center. Tighten all hardware assuring that the alignment indicator is not illuminated.

Cycle power to assure that the system powers up and goes to the ON state (alignment indicator is OFF)

Safety Instructions—Maintenance



ATTENTION: Never operate the GuardShield before carrying out the following inspection. Improper inspection can lead to serious or even deadly injury.

Note:

- For safety reasons all inspection results should be recorded.
- Only persons, who clearly understand the functioning of the GuardShield and of the machine, may carry out an inspection.
- If installer, planning engineer and operator are different people, make sure that the user has sufficient information available to carry out the inspection.

Daily Inspection

- Approach to hazardous machine parts must only be possible through passage through the protective field of GuardShield.
- Operators cannot step through the sensing area while working on dangerous machine parts.
- The safety distance of the application is bigger than the calculated value.
- The optic front cover is neither scratched nor dirty.

Operate the machine and check, if the hazardous movement will stop under the following circumstances.

- The protective field is interrupted.
- Hazardous machine movement stops immediately, if the protective field is interrupted by the test rod directly in front of the transmitter, directly in front of the receiver and in the middle between transmitter and receiver.
- No hazardous machine movement while the test rod is anywhere within the protective field.
- The power supply of the GuardShield is turned off.

IMPORTANT: If any of the above conditions do not result in the hazardous motion of the machine ceasing, do not allow the protected machine to be placed in operation.

Six-Month Inspection

Check the following items every six months or whenever a machine setting was changed.

1. Machine stops or does not obstruct any safety function.
2. The latest machine or connection modifications have no effect on the control system.
3. The outputs of the GuardShield are properly connected to the machine.
4. The total response time of the machine is shorter than the calculated value.
5. Cables and plugs of the GuardShield are in flawless condition.
6. Mounting brackets, caps and cables are tightly secured.

Cleaning

If the optic front cover of the GuardShield is dirty, the outputs of the GuardShield turn off. Take a clean, soft cloth and rub without pressure. Do not apply aggressive, abrasive or scratching cleansing agents, which might attack the surface.

GuardShield Safety Light Curtain Installation Instructions

Technical Specifications

Light Beams	8 – 176	
Protective Field	160mm – 1760mm (6.3in - 69.29in) in 160mm (6.3in) increments	
Resolution	14mm (0.55in), 30mm (1.18in)	
Range	14mm (0.55in); 0.3m to 7.0m (0.98ft – 22.9ft), 30mm (1.18in); 0.3m to 18.0m (0.98ft – 59.0ft)	
Response Time	OSSD – ON to OFF: (Reaction times); 20-25ms uncoded; 30-35ms coded	
Power Supply	24 V DC +/-20%; Power supply must meet the requirements of IEC 60204-1 and IEC 61496-1.	
Power Consumption	400mA max. (unloaded)	
IR Transmitter	Infrared LED (wave length 870 nm)	
Aperture Angle	Within $\pm 2.5^\circ$ for transmitter and receiver	
Operating Condition	IR transmitter ON	
Functions	Guard Only: Start Interlock: Restart Interlock: Relay Monitoring: Coding: Test Function:	On/Off operation with clear/obstructed detection area Interlock at start up—Reset by actuation of momentary N.O. pushbutton switch (or interruption/restoration of light curtain) Interlock at interruption of sensing field—Reset by actuation of momentary N.O. pushbutton switch Monitoring a switch contact of the installation May be necessary for multiplex alignment Triggering of system test via external switch
Inputs Transmitter	Machine Test Signal	Minimum duration 100ms Voltage level for Logic 0: 0 – 5V DC Voltage level for Logic Hi I: > 16V DC
Inputs Receiver	Start/Restart Interlock	Logic Lo Minimum duration 100ms; maximum duration 900ms Voltage level for Logic Lo 0: 0 – 5V DC Voltage level for Logic Hi I: > 16V DC
	MPCE	300ms after activation of OSSD Voltage level for Logic 0: 0 – 5V DC Voltage level for Logic Hi I: > 16V DC
Outputs:	Safety Outputs (OSSDs)	2 solid state outputs, max. switching capacity 500mA, short circuit protected, max. residual voltage 2V (excl. voltage drop through cables)
	Auxiliary Output	Solid state output, max. power consumption 500mA, max. residual voltage 2V—nonsafety output
Status Indicators Receiver	ON-state	Constant ON when system is in ON-state (green LED)
	OFF-state	Constant ON when system is in OFF-state (red LED)
	Blanking	Constant ON when Fixed Blanking is active
		Flashes, if Floating Blanking is active alone or together with Fixed Blanking (yellow LED)
Alignment Interlock	Lights up, if input signal is too weak (amber LED) Lights up when light curtain is in start or restart interlock mode (yellow LED)	
Status Indicators Sender	Power ON	Lights up, when voltage is on (amber LED)
	Emitting	Constant ON when transmitter is active (yellow LED)
QD Connectors	Transmitter: M12 plug 4 pin; receiver: M12 plug 8 pin	
Cable Length	Maximum 100 feet (30m)	
Ambient Temperature	During operation: -10°C to 55°C (14°F to 131°F); For storage: -25°C to 75°C (-13°F to 167°F)	
Humidity of the Air	Up to 95% (without condensation) between 20°C and 55°C (68°F and 131°F)	
Enclosure Rating	IP65	
Vibration Resistance	Per IEC 61496-1, IEC 60068-2-6 Frequency 10-55Hz Amplitude 0.35mm	
Shock	Per IEC 61496-1, IEC 60068-2-29 Acceleration 10g, Duration 16ms	
Material	Housing: Aluminum; Cover: PMMA (acrylic)	
Dimensions (cross section)	Approx. 40mm x 50mm (1.57in x 1.96in)	
Accessories Included	Test rod, mounting brackets, operating instructions, security tool	
Approvals	IEC 61496 Parts 1 and 2, UL 61496 Parts 1 and 2, UL 1998	
Transmitter Wave Length	870nm	

GuardShield Safety Light Curtain Installation Instructions

GuardShield Catalog Numbers

Sensor Pair	Transmitter	Receiver	Resolution—mm (in)	No. of Beams	Protective Heights—mm (in)	Pair Weight—kg (lbs)
440L-P4J0160YD	440L-T4J0160YD	440L-R4J0160YD	14 (0.55)	16	160 (6.3)	0.9 (1.9)
440L-P4J0320YD	440L-T4J0320YD	440L-R4J0320YD	14 (0.55)	32	320 (12.59)	1.1 (2.4)
440L-P4J0480YD	440L-T4J0480YD	440L-R4J0480YD	14 (0.55)	48	480 (18.89)	1.6 (3.5)
440L-P4J0640YD	440L-T4J0640YD	440L-R4J0640YD	14 (0.55)	64	640 (25.19)	2.0 (4.4)
440L-P4J0800YD	440L-T4J0800YD	440L-R4J0800YD	14 (0.55)	80	800 (31.49)	2.5 (5.5)
440L-P4J0960YD	440L-T4J0960YD	440L-R4J0960YD	14 (0.55)	96	960 (37.79)	2.9 (6.4)
440L-P4J1120YD	440L-T4J1120YD	440L-R4J1120YD	14 (0.55)	112	1120 (44.09)	3.4 (7.5)
440L-P4J1280YD	440L-T4J1280YD	440L-R4J1280YD	14 (0.55)	128	1280 (50.39)	3.8 (8.4)
440L-P4J1440YD	440L-T4J1440YD	440L-R4J1440YD	14 (0.55)	144	1440 (56.69)	4.3 (9.5)
440L-P4J1600YD	440L-T4J1600YD	440L-R4J1600YD	14 (0.55)	160	1600 (62.99)	4.7 (10.4)
440L-P4J1760YD	440L-T4J1760YD	440L-R4J1760YD	14 (0.55)	176	1760 (69.29)	5.2 (11.5)
440L-P4K0160YD	440L-T4K0160YD	440L-R4K0160YD	30 (1.18)	8	160 (6.3)	0.9 (1.9)
440L-P4K0320YD	440L-T4K0320YD	440L-R4K0320YD	30 (1.18)	16	320 (12.59)	1.1 (2.4)
440L-P4K0480YD	440L-T4K0480YD	440L-R4K0480YD	30 (1.18)	24	480 (18.89)	1.6 (3.5)
440L-P4K0640YD	440L-T4K0640YD	440L-R4K0640YD	30 (1.18)	32	640 (25.19)	2.0 (4.4)
440L-P4K0800YD	440L-T4K0800YD	440L-R4K0800YD	30 (1.18)	40	800 (31.49)	2.5 (5.5)
440L-P4K0960YD	440L-T4K0960YD	440L-R4K0960YD	30 (1.18)	48	960 (37.79)	2.9 (6.4)
440L-P4K1120YD	440L-T4K1120YD	440L-R4K1120YD	30 (1.18)	56	1120 (44.09)	3.4 (7.5)
440L-P4K1280YD	440L-T4K1280YD	440L-R4K1280YD	30 (1.18)	64	1280 (50.39)	3.8 (8.4)
440L-P4K1440YD	440L-T4K1440YD	440L-R4K1440YD	30 (1.18)	72	1440 (56.69)	4.3 (9.5)
440L-P4K1600YD	440L-T4K1600YD	440L-R4K1600YD	30 (1.18)	80	1600 (62.99)	4.7 (10.4)
440L-P4K1760YD	440L-T4K1760YD	440L-R4K1760YD	30 (1.18)	88	1760 (69.29)	5.2 (11.5)

Catalog Number Explanation

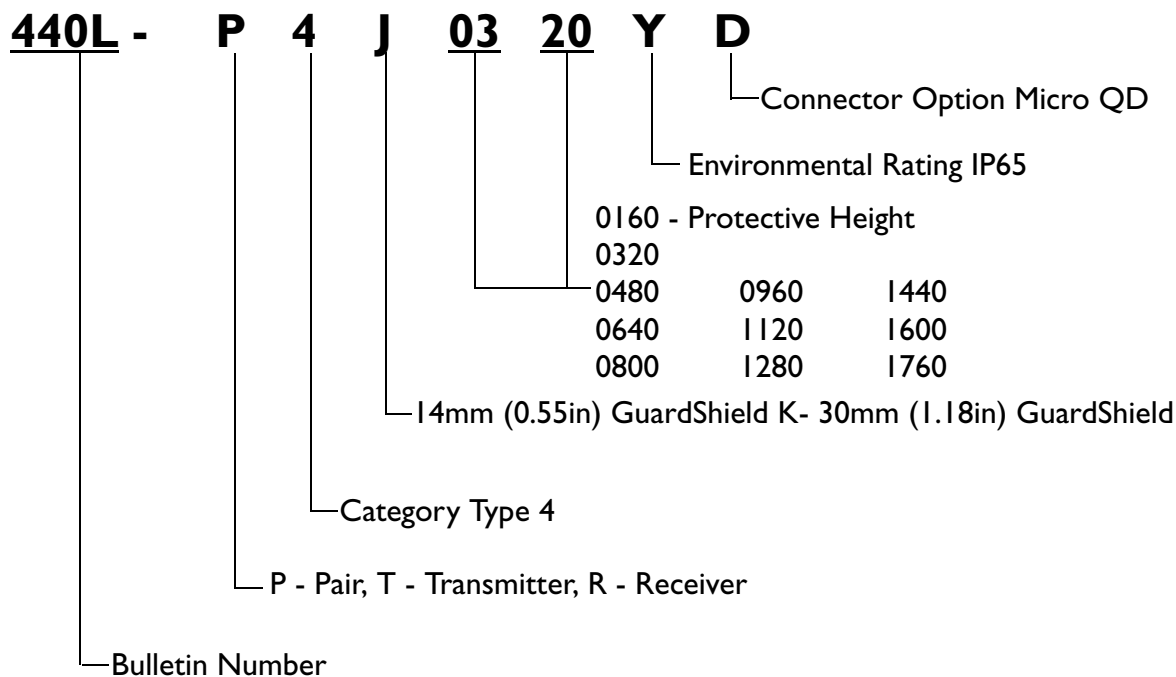

GuardShield Safety Light Curtain Installation Instructions

Dimensions—mm (in)

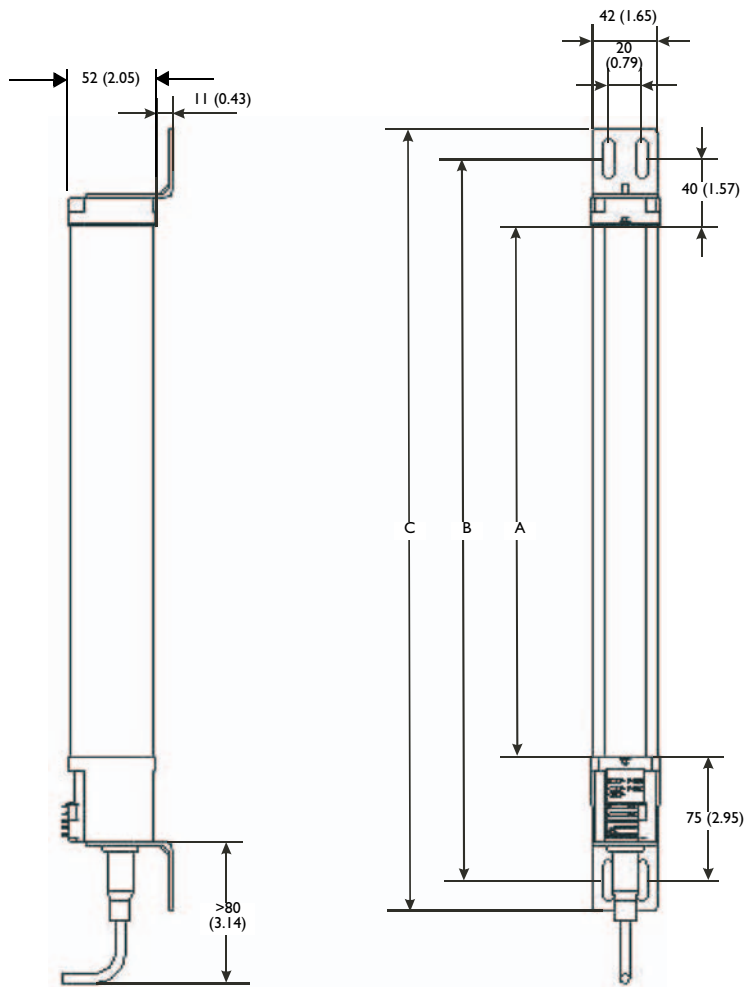

Type	A Protective Height	B Mounting Value	C Total Length
440L-P4J0160YD	160 ±0.5 (6.3) ±0.02	276 (10.9)	312 ±1.5 (12.3) ±0.06
440L-P4J0320YD	320 ±0.5 (12.6) ±0.02	436 (17.2)	472 ±1.5 (18.6) ±0.06
440L-P4J0480YD	480 ±0.5 (18.9) ±0.02	596 (28.5)	632 ±1.5 (24.9) ±0.06
440L-P4J0640YD	640 ±0.5 (25.2) ±0.02	756 (29.8)	792 ±1.5 (31.2) ±0.06
440L-P4J0800YD	800 ±0.6 (31.5) ±0.02	916 (36.1)	952 ±1.5 (37.5) ±0.06
440L-P4J0960YD	960 ±0.6 (37.8) ±0.02	1076 (42.4)	1112 ±1.5 (43.8) ±0.06
440L-P4JI120YD	1120 ±0.6 (44.1) ±0.02	1236 (48.7)	1272 ±1.8 (50.1) ±0.07
440L-P4JI280YD	1280 ±0.7 (50.4) ±0.02	1396 (55.0)	1432 ±1.8 (56.4) ±0.07
440L-P4JI440YD	1440 ±0.7 (56.7) ±0.03	1556 (61.3)	1592 ±1.8 (62.7) ±0.07
440L-P4JI600YD	1600 ±0.8 (63.0) ±0.03	1716 (67.6)	1752 ±2.0 (69.0) ±0.08
440L-P4JI760YD	1760 ±0.8 (69.3) ±0.03	1876 (73.9)	1912 ±2.0 (75.3) ±0.08

GuardShield Remote Teach

Introduction

The GuardShield Remote Teach system provides a remote means of changing a fixed blanking configuration within the GuardShield safety light curtain. This keyswitch box eliminates the need to open the GuardShield receiver door and perform the Teach function.

When a machine setup has been changed, which requires a new fixed blanking field to be configured, the GuardShield Remote Teach box is the ideal solution.

An IP65 metal keyswitch box is designed to be located in the vicinity of the GuardShield light curtain receiver. The Remote Teach box should be mounted in such a way as to allow the operator performing the Teach function a clear view of the area being blanked out.

The GuardShield receiver requires a modified right angle mounting bracket to fit around the cable gland hardware on the receiver endcap. This bracket is supplied with each GuardShield remote teach receiver.

The GuardShield Remote Teach Box system consists of the following:

- Remote teach keyswitch box with mounting plate and two keys
- GuardShield transmitter
- Two meter patchcord for connection between the 4 pin pigtail connector and the remote teach box.
- GuardShield receiver with a 10-inch dual connector pigtail. The dual connector contains a 4-pin micro qd as well as a standard 8-pin quick-disconnect GuardShield Receiver.
- Modified mounting bracket for Receiver bottom endcap

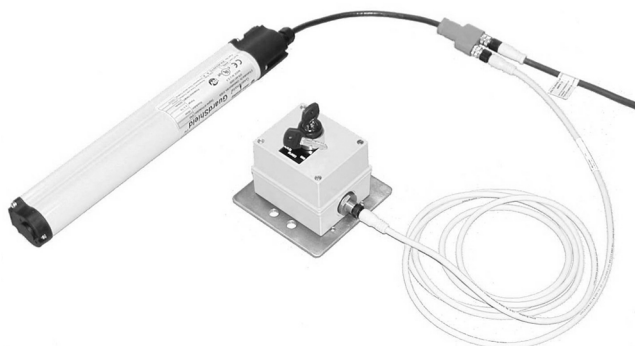

Figure 1: GuardShield Remote Teach Components

Note: The GuardShield remote teach box can not be retrofitted. It is possible to purchase the components separately. If a GuardShield system has already been purchased, the transmitter is a standard transmitter. The receiver part numbers vary by protective height. Refer to the Remote Teach System table for a list of component parts of a remote teach system.

System Delivery

The GuardShield Remote Teach system is delivered with the GuardShield transmitter and receiver configured in the standard GuardShield operating mode of “Guard Only,” which is Automatic reset, and all features not activated.

The 2 meter patchcord (889D-F4ACDM-2), Remote Teach (440L-M8600) keyswitch box and mounting hardware are packaged with each GuardShield Remote Teach system along with a standard GuardShield transmitter and remote teach receiver.

Remote Teach Box—KeySwitch Positions

The GuardShield remote teach box utilizes a Rockwell Automation 800EM series, 3-position IP66 rate keyswitch. There are three keyswitch positions on the GuardShield Remote Teach box as shown below.

RUN: This keyswitch position is required for the GuardShield light curtain to operate in its normal operating mode.

CONFIGURE: This keyswitch position simulates the opening of the GuardShield’s dipswitch door. This position sends a signal to the GuardShield’s firmware to change from the RUN mode of operation to a configuration mode of operation in this mode, all outputs are in the OFF state.

TEACH: This keyswitch position performs the function of changing the operating mode configuration of the GuardShield light curtain.

CONFIGURE

RUN TEACH

Figure 2: KeySwitch Label Positions

System Installation

The GuardShield light curtain transmitter and receiver should be properly mounted to the machinery to be guarded per the GuardShield Installation Instructions.

After aligning the GuardShield safety light curtains and attaining a “Green” state, the GuardShield safety light curtain is transmitting infrared light and the GuardShield receiver OSSDs are high, it is possible to reconfigure the GuardShield.

Using the T8 Torx bit supplied with each GuardShield bracket kit, open the GuardShield Receiver door and set dipswitch 4 to the ON position. This dipswitch allows the activation and configuration of a monitored fixed blanked area within the GuardShield’s protective height.

Make any additional dipswitch settings at this time.

NOTE: If EDM or Reset functions are to be configured through dipswitch settings, assure that the proper receiver wire connections are made.

GuardShield Safety Light Curtain Installation Instructions

IMPORTANT: It is not possible to blank out the synch beam, which is the first beam adjacent to the GuardShield's diagnostic LEDs.

NOTE: If the Transmitter's configuration needs to be changed from the factory settings, set the dipswitches in the transmitter and follow the standard teach process

Remote Teach Procedure

1. Position object in the GuardShield sensing field, assure that the synchronization beam is not obstructed
2. Turn keyswitch to the configure position. The receiver's red LED will be flashing and the yellow blanking LED will be illuminated.
3. Turn and hold keyswitch in the Teach position
4. The GuardShield receiver's yellow blanking LED will begin flashing.
5. When the yellow blanking LED stops flashing, **release the keyswitch to the configure position within 2 seconds.**
6. The GuardShield receiver's yellow blanking LED will flash 3 times to confirm that the new fixed blanking configuration has been set.
7. Turn the keyswitch to the RUN position, the green LED on the GuardShield receiver will illuminate.
8. Using the supplied test rod, confirm the fixed blanking area and any other settings are configured as expected.

It is possible to configure and activate both fixed and 1 or 2 beam floating blanking on the GuardShield light curtain.

NOTE: Once the GuardShield is configured by changing factory dipswitch positions and performing the Teach function, the GuardShield will be reconfigured. Any future Teach procedure will only change the configuration of the fixed blanking area.

IMPORTANT: After teaching the GuardShield a new configuration, confirm that the configuration that was expected to be configured has actually been configured.

IMPORTANT: Fixed blanking creates a "hole" in the detection area of the GuardShield. It is necessary to assure that access to the hazard being protected against is prevented by means of barrier guarding. It should not be possible to access the hazard through the fixed blanked area.

Remote Teach System

Catalog Number	Description
440L-S4J0160YR	GuardShield Remote Teach system, 160mm protective height 14mm resolution
440L-S4J0320YR	GuardShield Remote Teach system, 320mm protective height 14mm resolution
440L-S4J0480YR	GuardShield Remote Teach system, 480mm protective height 14mm resolution
440L-S4J0640YR	GuardShield Remote Teach system, 640mm protective height 14mm resolution
440L-S4J0800YR	GuardShield Remote Teach system, 800mm protective height 14mm resolution
440L-S4J0960YR	GuardShield Remote Teach system, 960mm protective height 14mm resolution
440L-S4J1120YR	GuardShield Remote Teach system, 1120mm protective height 14mm resolution
440L-S4J1280YR	GuardShield Remote Teach system, 1280mm protective height 14mm resolution
440L-S4J1440YR	GuardShield Remote Teach system, 1440mm protective height 14mm resolution
440L-S4J1600YR	GuardShield Remote Teach system, 1600mm protective height 14mm resolution
440L-S4J1760YR	GuardShield Remote Teach system, 1760mm protective height 14mm resolution
440L-S4K0160YR	GuardShield Remote Teach system, 160mm protective height 30mm resolution
440L-S4K0320YR	GuardShield Remote Teach system, 320mm protective height 30mm resolution
440L-S4K0480YR	GuardShield Remote Teach system, 480mm protective height 30mm resolution
440L-S4K0640YR	GuardShield Remote Teach system, 640mm protective height 30mm resolution
440L-S4K0800YR	GuardShield Remote Teach system, 800mm protective height 30mm resolution
440L-S4K0960YR	GuardShield Remote Teach system, 960mm protective height 30mm resolution
440L-S4K1120YR	GuardShield Remote Teach system, 1120mm protective height 30mm resolution
440L-S4K1280YR	GuardShield Remote Teach system, 1280mm protective height 30mm resolution
440L-S4K1440YR	GuardShield Remote Teach system, 1440mm protective height 30mm resolution
440L-S4K1600YR	GuardShield Remote Teach system, 1600mm protective height 30mm resolution
440L-S4K1760YR	GuardShield Remote Teach system, 1760mm protective height 30mm resolution

Remote Teach System Component Parts

Catalog Number	Description
800E-AKR3825	Replacement Key
440L-M8600	Remote Teach Box
889D-F4ACDM-2	2 meter patchcord

GuardShield Safety Light Curtain Installation Instructions

Remote Teach Receiver

Catalog Number	Description
440L-R4J0160YR	Receiver, GuardShield Remote Teach, 160mm protective height, 14mm resolution
440L-R4J0320YR	Receiver, GuardShield Remote Teach, 320mm protective height, 14mm resolution
440L-R4J0480YR	Receiver, GuardShield Remote Teach, 480mm protective height, 14mm resolution
440L-R4J0640YR	Receiver, GuardShield Remote Teach, 640mm protective height, 14mm resolution
440L-R4J0800YR	Receiver, GuardShield Remote Teach, 800mm protective height, 14mm resolution
440L-R4J0960YR	Receiver, GuardShield Remote Teach, 960mm protective height, 14mm resolution
440L-R4J1120YR	Receiver, GuardShield Remote Teach, 1120mm protective height, 14mm resolution
440L-R4J1280YR	Receiver, GuardShield Remote Teach, 1280mm protective height, 14mm resolution
440L-R4J1440YR	Receiver, GuardShield Remote Teach, 1440mm protective height, 14mm resolution
440L-R4J1600YR	Receiver, GuardShield Remote Teach, 1600mm protective height, 14mm resolution
440L-R4J1760YR	Receiver, GuardShield Remote Teach, 1760mm protective height, 14mm resolution
440L-R4K0160YR	Receiver, GuardShield Remote Teach, 160mm protective height, 30mm resolution
440L-R4K0320YR	Receiver, GuardShield Remote Teach, 320mm protective height, 30mm resolution
440L-R4K0480YR	Receiver, GuardShield Remote Teach, 480mm protective height, 30mm resolution
440L-R4K0640YR	Receiver, GuardShield Remote Teach, 640mm protective height, 30mm resolution
440L-R4K0800YR	Receiver, GuardShield Remote Teach, 800mm protective height, 30mm resolution
440L-R4K0960YR	Receiver, GuardShield Remote Teach, 960mm protective height, 30mm resolution
440L-R4K1120YR	Receiver, GuardShield Remote Teach, 1120mm protective height, 30mm resolution
440L-R4K1280YR	Receiver, GuardShield Remote Teach, 1280mm protective height, 30mm resolution
440L-R4K1440YR	Receiver, GuardShield Remote Teach, 1440mm protective height, 30mm resolution
440L-R4K1600YR	Receiver, GuardShield Remote Teach, 1600mm protective height, 30mm resolution
440L-R4K1760YR	Receiver, GuardShield Remote Teach, 1760mm protective height, 30mm resolution

Dimensions—mm (inch)

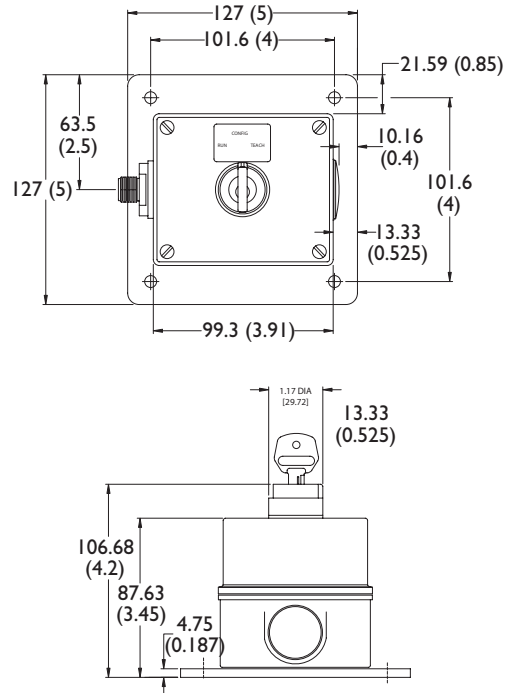

Accessories

Corner Mirrors

Protective Field Height— mm (in)	Catalog Number
160 (6.3)	440L-AMI200300
320 (12.5)	440L-AMI200450
480 (18.89)	440L-AMI200600
640 (25.19)	440L-AMI200750
800 (31.49)	440L-AMI200900
960 (37.79)	440L-AMI201050
1120 (44.09)	440L-AMI201200
1280 (50.39)	440L-AMI201350
1440 (56.69)	440L-AMI201500
1600 (62.99)	440L-AMI201650
1760 (69.29)	440L-AMI201800
Mirror Mounting Kit (2 required per mirror)	440L-AMI20BRK

GuardShield Safety Light Curtain Installation Instructions

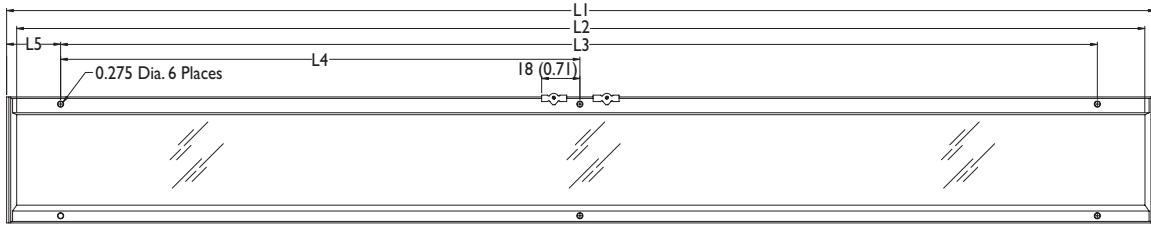

Shown
440L-AM1201500

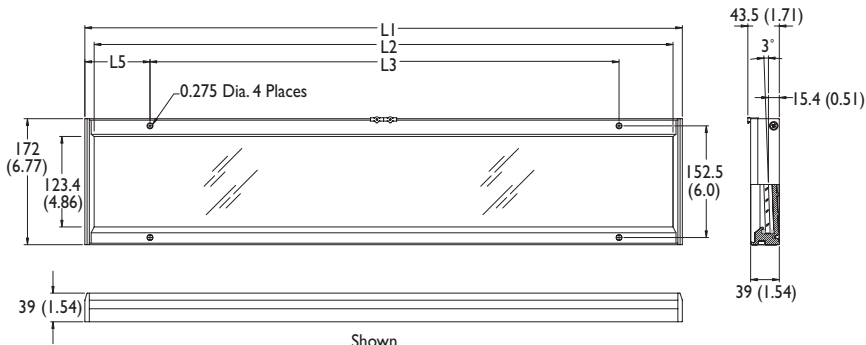

Shown
440L-AM1200750

Mounting Stand—440L-AMSTD

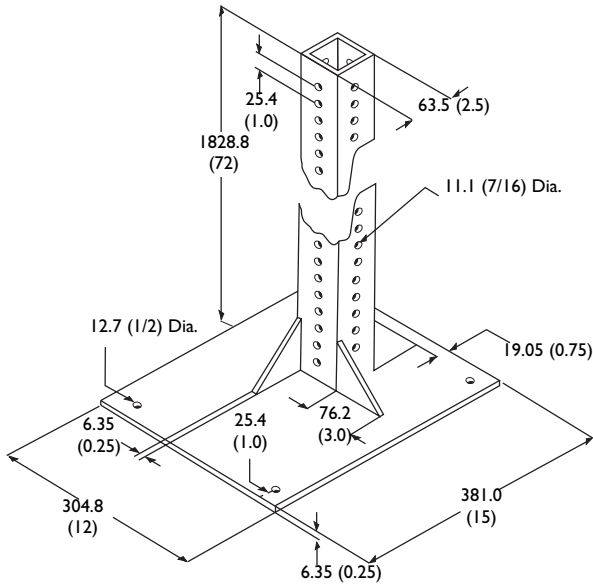

Laser Alignment Tool

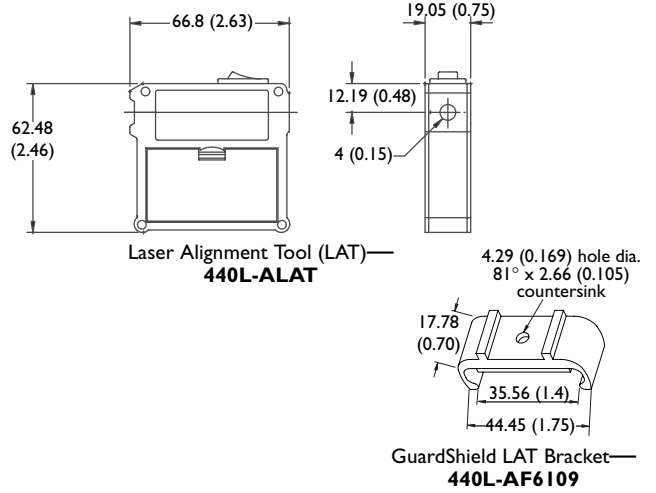

Weld Shields

The GuardShield weld shields are sold as pairs in the same lengths as the protective heights of the GuardShield safety light curtain.

These polycarbonate weld shields are designed as disposable devices whose purpose is to protect the front window of the GuardShield from damage.

Dimensions—mm (inches)

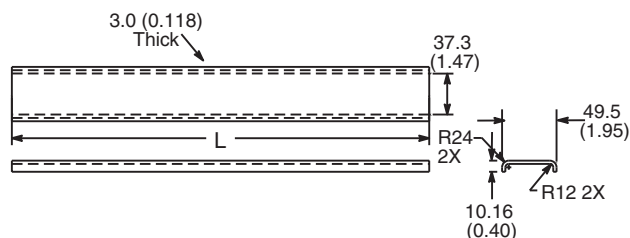

GS Weld Shield Catalog Numbers	Dimension "L" mm (in)
440L-AGWS0160	175.3 (6.9)
440L-AGWS0320	335.3 (13.20)
440L-AGWS0480	495.3 (19.50)
440L-AGWS0640	655.3 (25.80)
440L-AGWS0800	815.3 (32.10)
440L-AGWS0960	975.4 (38.40)
440L-AGWS1120	1135.4 (44.70)
440L-AGWS1280	1295.4 (51.00)
440L-AGWS1440	1455.4 (57.30)
440L-AGWS1600	1615.4 (63.60)
440L-AGWS1760	1778 (70.00)

For Connection to Transmitter

Catalog Number	Description
889D-F4AC-2	4-pin DC Micro Straight Female Cordset, 2 (6.5)
889D-F4AC-5	4-pin DC Micro Straight Female Cordset, 5 (16.4)
889D-F4AC-10	4-pin DC Micro Straight Female Cordset, 10 (32.8)
889D-F4AC-15	4-pin DC Micro Straight Female Cordset, 15 (49.2)
889D-F4AC-20	4-pin DC Micro Straight Female Cordset, 20 (65.6)
889D-F4AC-30	4-pin DC Micro Straight Female Cordset, 30 (98.4)
889D-R4AC-2	4-pin DC Micro Right Angle Female Cordset, 2 (6.5)
889D-R4AC-5	4-pin DC Micro Right Angle Female Cordset, 5 (16.4)
889D-R4AC-10	4-pin DC Micro Right Angle Female Cordset, 10 (32.8)
889D-R4AC-15	4-pin DC Micro Right Angle Female Cordset, 15 (49.2)
889D-R4AC-20	4-pin DC Micro Right Angle Female Cordset, 20 (65.6)
889D-R4AC-30	4-pin DC Micro Right Angle Female Cordset, 30 (98.4)

For Connection to Receiver

Catalog Number	Description—m (ft)
889D-F8AB-2	8-pin DC Micro Straight Female Cordset, 2 (6.5)
889D-F8AB-5	8-pin DC Micro Straight Female Cordset, 5 (16.4)
889D-F8AB-10	8-pin DC Micro Straight Female Cordset, 10 (32.8)
889D-F8AB-15	8-pin DC Micro Straight Female Cordset, 15 (49.2)
889D-F8AB-20	8-pin DC Micro Straight Female Cordset, 20 (65.6)
889D-F8AB-30	8-pin DC Micro Straight Female Cordset, 30 (98.4)
889D-R8AB-2	8-pin/8-wire DC Micro Right Angle Female Cordset, 2 (6.5)
889D-R8AB-5	8-pin/8-wire DC Micro Right Angle Female Cordset, 5 (16.4)
889D-R8AB-10	8-pin/8-wire DC Micro Right Angle Female Cordset, 10 (32.8)
889D-R8AB-15	8-pin/8-wire DC Micro Right Angle Female Cordset, 15 (49.2)
889D-R8AB-20	8-pin/8-wire DC Micro Right Angle Female Cordset, 20 (65.6)
889D-R8AB-30	8-pin/8-wire DC Micro Right Angle Female Cordset, 30 (98.4)

EC Declaration of Conformity

The undersigned, representing the following supplier

Rockwell Automation/Allen-Bradley
2 Executive Drive
Chelmsford, MA 01824 -- USA

and the authorized representative established within the community

Rockwell Automation, Subsidiary of
Rockwell International GmbH
Düsselder Straße 15
D-42781 Haan, Germany

herewith declare that the Products
Product identification (brand and
catalogue number/part number):

440L Safety Light Curtain
Allen-Bradley/GuardShield 440L-P4 and 440L-S4 light curtain
models with 14mm and 30mm resolution, (reference the attached list of
catalogue numbers)

Product Safety Function:

440L-P4 and 440L-S4 safety light curtains are active opto-electronic protection devices (AOPD) with resolutions of 14mm and 30mm. These safety light curtains are self-checking and belong to Safety Category 4.

are in conformity with the provisions of the following EC Directive(s) when installed in accordance with the installation instructions contained in the product documentation:

98/37/EC

Machine Safety Directive

89/336/EEC

EMC Directive as amended by 92/31/EEC, 93/68/EEC

and complies with the provisions of the following harmonized standards:

EN 954-1:1996

Safety of machinery - Safety-related parts of control systems – Part 1:
General principles for design

EN 61496-1:1997

Safety of machinery - Electrosensitive protective equipment - Part 1:
General requirements and tests

IEC 61496-2:1997

Safety of machinery - Electro-sensitive protective equipment - Part 2: Particular requirements for equipment using active opto-electronic protective devices (AOPDs)

Conformance of a type sample belonging to the above-mentioned product family with the regulations from the EC machine directives has been certified by:

TÜV NORD CERT GmbH & Co. KG
Am TÜV 1
30519 Hannover, Germany

EC type sample test No.

04/YMA551743 dated 2004-29-10 GuardShield Remote Teach
02/YMA134740 dated 2002-24-07 GuardShield

Conformance via a Technical Construction File (TCF) is declared using all or parts of the following standards (EMC only):

EN 61496-1:1997

Safety of machinery - Electrosensitive protective equipment - Part 1:
General requirements and tests

EN 55022: 1998

Information technology equipment-Radio disturbance characteristics-Limits and methods of measurement

EMC Technical Construction File

TCF Number 75014-942, dated 25-Oct – 2004 GuardShield Remote Teach

TCF Number: 75014-941, dated 19-Dec-2002 GuardShield

Maintained at:

Rockwell Automation
2 Executive Drive
Chelmsford, MA 01824 -- USA

Competent Body:

TÜV PRODUCT SERVICE GMBH
Zertifizierstelle – Ridlerstrasse 65
80339 München, Germany

Supplier:

Authorized Representative in the Community:

Signature

Name: H Ed Giachelli
Position: Quality Manager
Date: 26-Oct-2004

i.V.

Signature

Name: Viktor Schiffer
Position: Engineering Manager
Date: 28-Oct-2004



Allen-Bradley

GuardMaster®

Please contact us for Technical Assistance:

In the U.S.: 1-440-646-5800

Outside U.S.: 001-440-646-5800

On line: <http://www.ab.com/safety>

www.rockwellautomation.com

<http://www.ab.com/safety>

Corporate Headquarters

Rockwell Automation, 777 East Wisconsin Avenue, Suite 1400, Milwaukee, WI, 53202-5302 USA, Tel: (1) 414.212.5200, Fax: (1) 414.212.5201

Headquarters for Allen-Bradley Products, Rockwell Software Products and Global Manufacturing Solutions

Americas: Rockwell Automation, 1201 South Second Street, Milwaukee, WI 53204-2496 USA, Tel: (1) 414.382.2000, Fax: (1) 414.382.4444

Europe: Rockwell Automation SA/NV, Vorstlaan/Boulevard du Souverain 36-BP 3A/B, 1170 Brussels, Belgium, Tel: (32) 2 663 0600, Fax: (32) 2 663 0640

Asia Pacific: Rockwell Automation, 27/F Citicorp Centre, 18 Whitfield Road, Causeway Bay, Hong Kong, Tel: (852) 2887 4788, Fax: (852) 2508 1846

Headquarters for Dodge and Reliance Electric Products

Americas: Rockwell Automation, 6040 Ponders Court, Greenville, SC 29615-4617 USA, Tel: (1) 864.297.4800, Fax: (1) 864.281.2433

Europe: Rockwell Automation, Brühlstraße 22, D-74834 Elzta-Dallau, Germany, Tel: (49) 6261 9410, Fax: (49) 6261 17741

Asia Pacific: Rockwell Automation, 55 Newton Road, #11-01/02 Revenue House, Singapore 307987, Tel: (65) 351 6723, Fax: (65) 355 1733