

## INSTALLATION INSTRUCTIONS

## MONTAGEANLEITUNG / NOTICE D'INSTALLATION

**!** The switch head screws must be fully tightened before the switch is connected to the machine control circuit.  
Once the switch is connected the head must not be removed. Removing the head may cause a dangerous situation.  
Die Schrauben am Schalterkopf sind fest anzuziehen, bevor der Schalter in den Stromkreis der Maschine angeschlossen wird. Nachdem der Schalter angeschlossen wurde, darf der Kopf nicht mehr abgenommen werden. Ein Abnehmen des Kopfes kann einen gefährbringenden Zustand hervorrufen.  
Les vis de fixation de la tête du détecteur doivent être serrées avant de raccorder ce dernier au boîtier d'autocontrôle de la machine. Une fois que le détecteur est raccordé, la tête ne doit plus être démontée. Démonteur la tête peut engendrer une situation dangereuse.

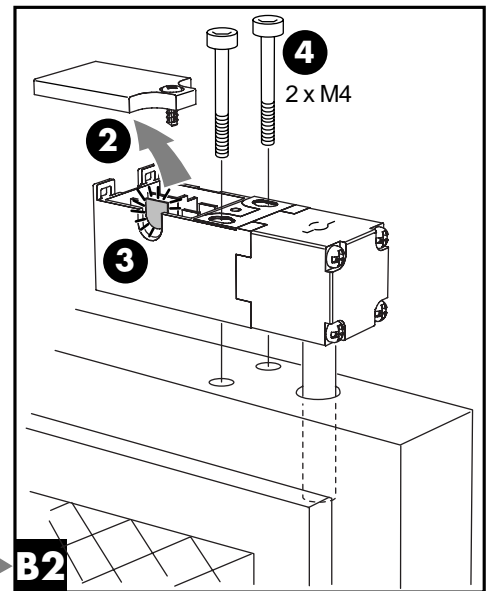

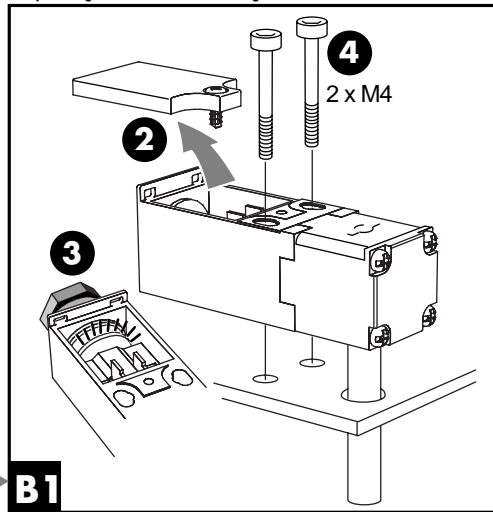
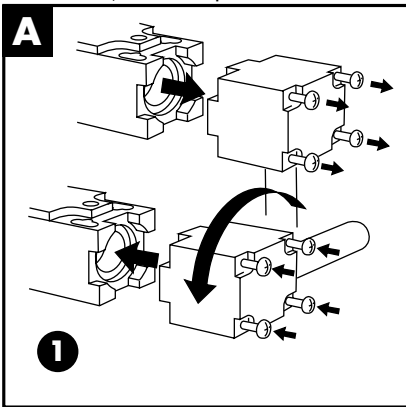
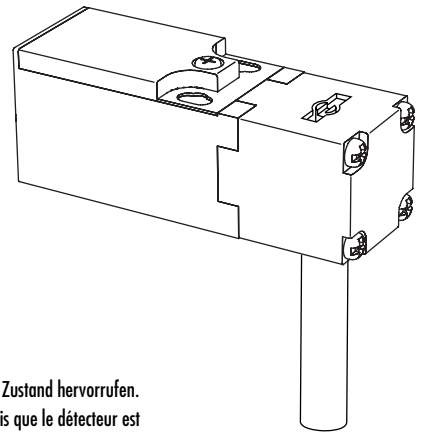

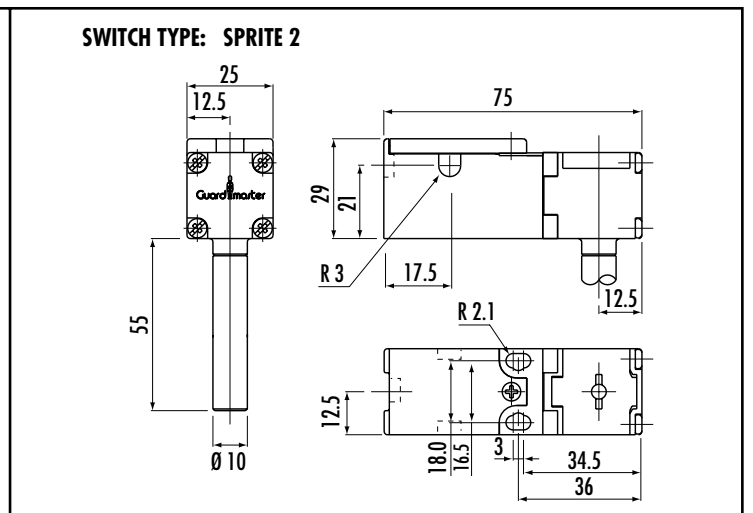
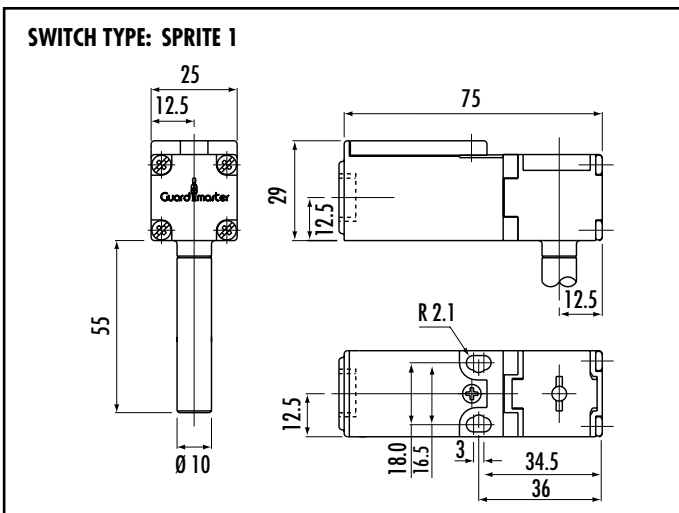
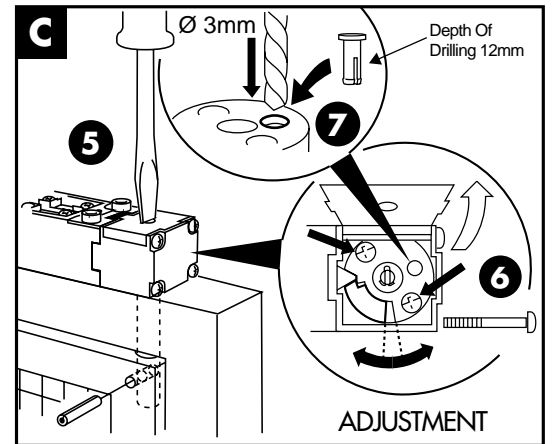
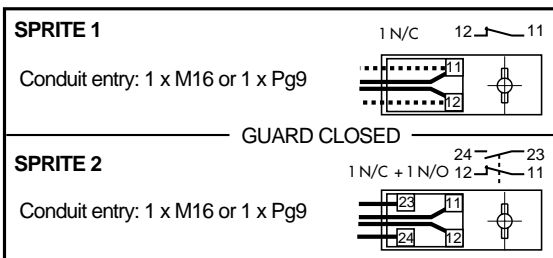
**ATTENTION:** The maximum operating angle for positive opening of the unadjusted cam mechanism is 11°. The cam can be adjusted down to a minimum angle of 3° and after adjustment must be fixed using the pin.  
**ACHTUNG:** Der max Schaltwinkel bis zur Zwangsöffnung des nicht-justierten Nockenmechanismus beträgt 11°. Der Nocken kann auf einen minimalen Winkel von 3° justiert werden. Nach Justierung ist eine Fixierung mit dem Stift vorzunehmen.  
**ATTENTION:** L'angle maximum d'opération pour l'ouverture d'un mécanisme à came mal ajusté est de 11°. La came peut être ajustée jusqu'à un angle minimum de 3° et doit ensuite être fixée à l'aide de la "punaise".







## Technical Specifications

## Technische Daten

## Specifications Techniques

Conforming to standards	EN60947-5-1, EN1088 GS-ET-15, BS5304
Safety contacts - Sprite 1	1 N/C positive break 
Sprite 2	1 N/C 1 N/O positive break
Utilization cat.	AC 15
a.c. (Ue)	500V 250V 100V
(Ie)	1A 2A 5A
d.c.	250V 0.5A, 24V 2A
Thermal current (Ith)	10A
Safety contact gap	>2 x2mm
Rtd. insulation voltage	(Ui) 500V
Rtd. impulse withstand voltage	(Uimp) 2500V
Pollution degree	3
Shaft rotation to achieve contact operation	Max 11°, Min 3° (adjustable)
Break contact min. torque	8 cNm
Case material	Self extinguishing glass reinforced Polyester.
Actuator material	Stainless steel
Protection	Sprite 1 IP67/ Sprite 2 IP30
Conduit entry - Sprite 1	1x M16 / 1 x PG9
Sprite 2	3 x break out points
Operating temperature	-25° to + 80°C 
Fixing	2 x M4
Mounting	Any position
Cleaning	May be high pressure steam cleaned
Mechanical life	>1 x 10 <sup>6</sup>

Vorschriften	EN60947-5-1, EN1088 GS-ET-15, BS5304
Sicherheitskontakte- Sprite 1	1 N/C zwangsgeführt 
Sprite 2	1 N/C 1 N/O zwangsgeführt
Verwendungskategorie	AC 15
a.c. (Ue)	500V 250V 100V
(Ie)	1A 2A 5A
d.c.	250V 0.5A, 24V 2A
Dauerstrom (Ith)	10A
Zwangsöffnungsweg	>2 x2mm
Nennisolationsspannung	(Ui) 500V
max. Impuls-Prüfspannung	(Uimp) 2500V
Verschmutzungsgrad	3
Öffnen der Kontakte bei Rotation der Schalterwelle	Max 11°, Min 3° (justierbar)
min. Drehmoment für Öffnerkontakt	8 cNm
Gehäuse	glasfaserverstärkter Polyester, selbstverlöschend, nichtrostender Stahl.
Betätigungsbügel	Stahl.
Schutzart	Sprite 1 IP67/ Sprite 2 IP30
Kabeleinführungen Sprite 1	1x M16 / 1 x PG9
Sprite 2	3 Ausbrechöffnungen
Betriebstemperatur	-25° to + 80°C 
Befestigung	2 x M4
Einbaulage	beliebig
Reinigung	hochdruckfest
mech. Lebensdauer	>1 x 10 <sup>6</sup>

Conforme aux standards	EN60947-5-1, EN1088 GS-ET-15, BS5304
Contacts de sécurité- Sprite 1	1 N/C rupture positive 
Sprite 2	1 N/C 1 N/O rupture positive
Catégorie d'utilisation	AC 15
a.c. (Ue)	500V 250V 100V
(Ie)	1A 2A 5A
d.c.	250V 0.5A, 24V 2A
Courant (Ith)	10A
Espace contacts de sécurité	>2 x2mm
Tension efficace	(Ui) 500V
Tension d'isolement	(Uimp) 2500V
Contacts auxiliaires	1N/O (version ECS1)
Degré de pollution	3
Rotation de l'arbre pour assurer le fonctionnement du contact	Max 11°, Min 3° (justable)
Rupture minimum du contact - Moment de torsion	8 cNm
Boîtier	Polyester renforcé de verre autoextinguible
Clé	Inox
Protection	Sprite 1 IP67/ Sprite 2 IP30
Entrée tube Sprite 1	1x M16 / 1 x PG9
Sprite 2	3 Amovible
Température	-25° to + 80°C
Fixation	2 x M4 
Montage	Toutes positions
Nettoyage	Peut-être nettoyé au jet haute pression,
Durée de vie mécanique	>1 x 10 <sup>6</sup>

### INFORMATION IN REGARD TO UL508

Use copper conductors only.  
Use polymeric conduit only.  
End of line device.  
Terminal tightening torque 9in/lbs.  
When used in elevated ambients, temperature rating of field wiring shall not be less than ambient.  
Electrical spec of rating code B600.  
Max current: 120V AC - make 30A, break 3A.  
240V AC - make 15A, break 1.5A.  
Max. V/A: make 3600, break 360.



**Allen-Bradley**

**Guardmaster®**