

Sipha Sensors

Installation Instructions

Installationsanleitung

Notice d'installation

Istruzioni per l'installazione

Instrucciones de instalación



Allen-Bradley



Drg. No: 32736 Issue 7
Change Note: 25391



www.ejaltd.com - www.ab.com/safety

Made by EJA Ltd, Wigan, UK

Installation must be in accordance with the following steps and stated specifications and should be carried out by suitably competent personnel. The unit is not to be used as a mechanical stop. Guard stops and guides must be fitted.

Adherence to the recommended maintenance instructions forms part of the warranty.

ATTENTION: The presence of spare actuators can compromise the integrity of safety systems. Personal injury or death, property damage or economic loss can result. Appropriate management controls, working procedures and alternative protective measures should be introduced to control their use and availability.

WARNING: Do not defeat, tamper, remove or bypass this unit. Severe injury to personnel could result.

Bei der Installation müssen die im Folgenden beschriebenen Anweisungen und angegebenen Spezifikationen eingehalten werden. Zudem darf die Installation nur von entsprechend qualifizierten Mitarbeitern ausgeführt werden. Das Gerät darf nicht als mechanische Sperre verwendet werden. Schutzgittersperren und -leitvorrichtungen müssen angebracht werden.

Werden die empfohlenen Wartungsanweisungen nicht eingehalten, entfällt die Gewährleistung. **ACHTUNG:** Ersatzbetätiger können die Integrität von Sicherheitssystemen beeinträchtigen. Körperverletzungen oder Tod sowie Sachschäden oder wirtschaftliche Verluste können die Folge sein. Es sind geeignete Bedienungselemente, Arbeitsabläufe und alternative Schutzmaßnahmen vorzusehen, um ihre Verwendung und Verfügbarkeit zu steuern.

WARNUNG: Nehmen Sie niemals Eingriffe am Gerät vor, und zerlegen, entfernen oder überbrücken Sie das Gerät nicht. Andernfalls können schwere Körperverletzungen die Folge sein.

L'installation doit être effectuée par un personnel qualifié conformément aux étapes et aux spécifications suivantes. Cet interrupteur ne doit pas être utilisé comme un arrêt mécanique. Installer des butées de porte et des dispositifs de guidage.

Le respect des instructions de maintenance recommandée est l'une des conditions de la garantie.

ATTENTION: la présence d'actionneurs supplémentaires peut compromettre l'intégrité des systèmes de sécurité et entraîner des blessures pouvant être mortelles, des dégâts matériels ou des pertes financières. Des contrôles de gestion, des procédures de travail, ainsi que des mesures de protection alternatives appropriées doivent être mis en place pour en contrôler l'utilisation et la disponibilité.

AVERTISSEMENT: ne pas entraver le fonctionnement de cet interrupteur, ne pas le modifier, le retirer ni le contourner au risque de s'exposer à de graves blessures.

Le operazioni di installazione devono essere eseguite da personale competente conformemente alle fasi qui di seguito illustrate nonché alle specifiche stabilite.

L'unità non va utilizzata come fermo meccanico. È necessario accoppiare i fermi e le guide della protezione. Il rispetto delle istruzioni di manutenzione raccomandate costituisce parte della garanzia. **ATTENZIONE:** la presenza di attuatori di riserva può compromettere l'integrità dei sistemi di sicurezza. Pericolo di infortuni o morte, di danni a oggetti o di perdite economiche. È opportuno svolgere adeguati controlli di gestione, procedure di lavoro e adottare altre misure di sicurezza appropriate per controllarne l'uso e la disponibilità.

ATTENZIONE: non forzare, manomettere, rimuovere o bypassare questa unità. Pericolo di gravi lesioni alle persone.

La instalación debe realizarse según los pasos siguientes y las especificaciones establecidas, y debe ser realizada por personal debidamente capacitado.

La unidad no debe usarse como dispositivo de paro mecánico. Los dispositivos de paros y guías de la guarda deben estar instalados. El cumplimiento de las instrucciones de mantenimiento recomendadas forma parte de la garantía. **ATENCIÓN:** la presencia de accionadores adicionales puede comprometer la integridad de los sistemas de seguridad. Pueden ocurrir lesiones personales o la muerte, daños materiales y pérdidas económicas. Deben introducirse controles de administración apropiados, procedimientos de trabajo y medidas de protección alternativas a fin de controlar su uso y disponibilidad.

ADVERTENCIA: No cambie ni manipule indebidamente, ni desmonte u omita esta unidad. Esto podría causar lesiones personales graves.

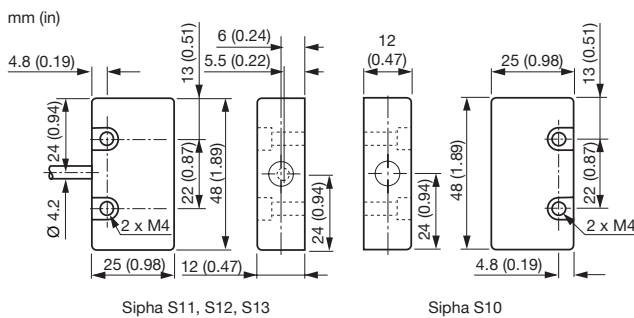

Sipha S11, S12, S13

Sipha S10

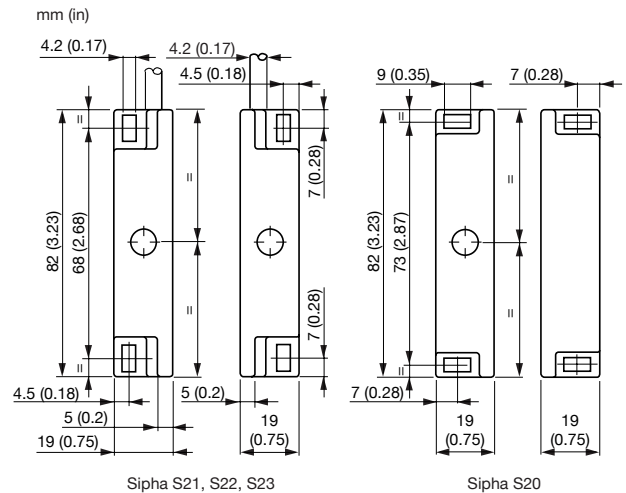

Sipha S21, S22, S23

Sipha S20

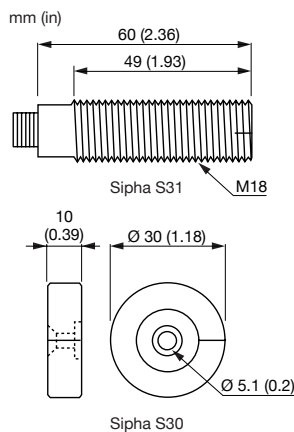

Sipha S31

Sipha S30

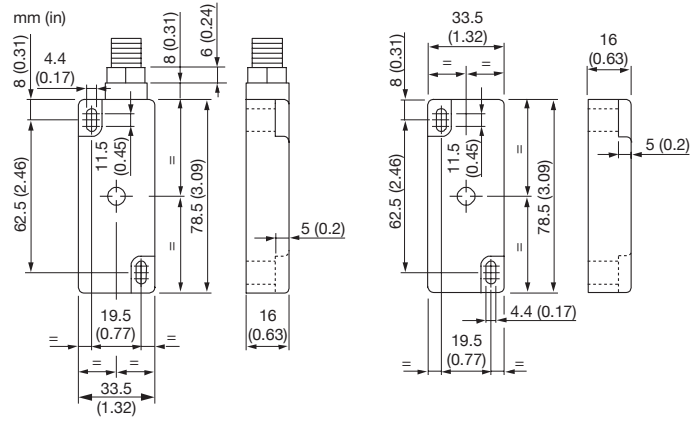

Sipha S42, S43

Sipha S40

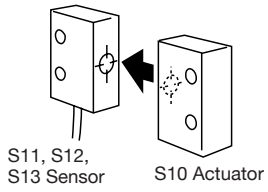
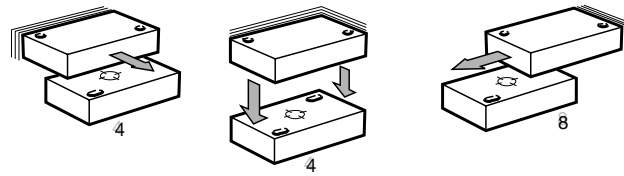
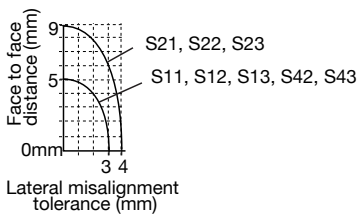

Sipha S11, S12, S13, S21, S22, S23, S42 & S43

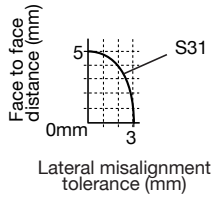
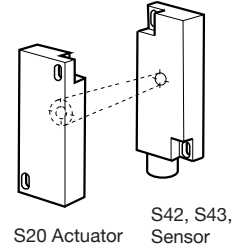
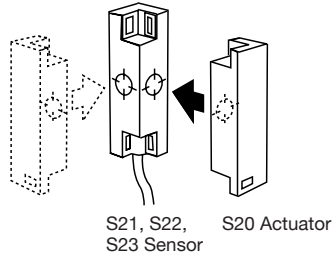

Sipha S31

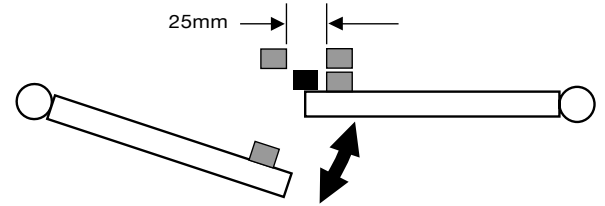
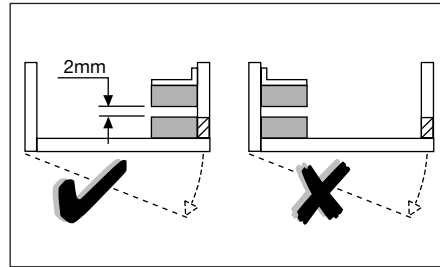
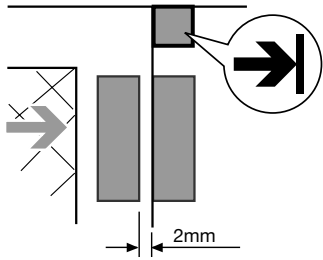
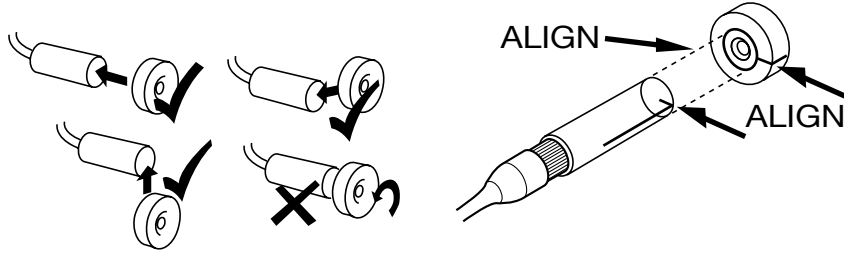

Sipha S11, S12, S13, S21, S22, S23, S42 & S43

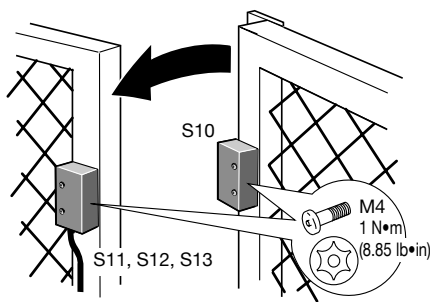

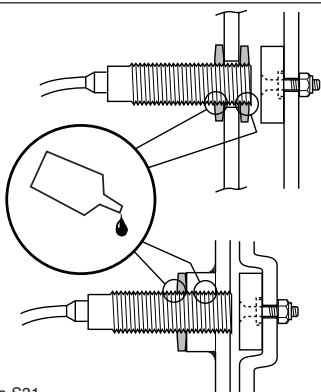
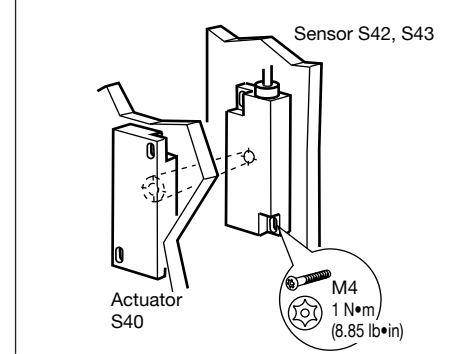
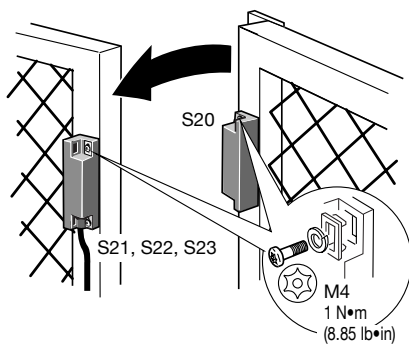

Sipha S11, S12, S13, S21, S22 & S23

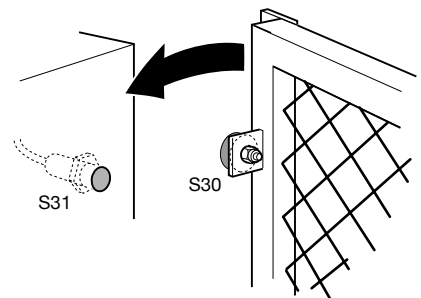
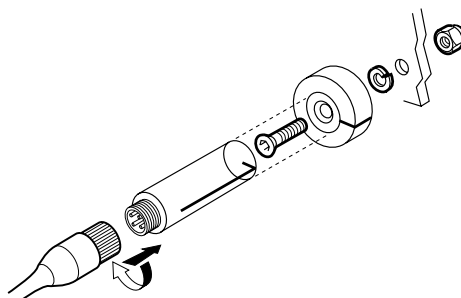

Sipha S31

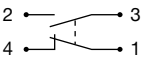
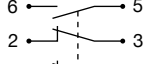
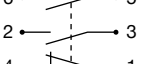
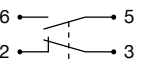
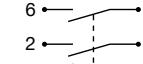

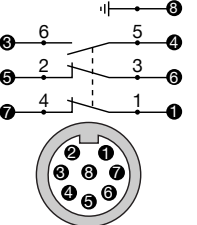
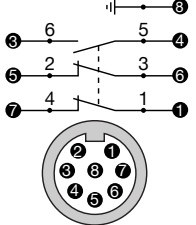
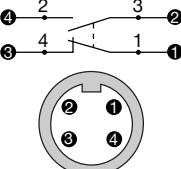
 <p>Sipa S11/S21</p>	 <p>Sipa S12/S22</p>	 <p>Sipa S13/S23</p>	 <p>Sipa S42</p>	 <p>Sipa S43</p>	
<p>Sipa S11, S12, S13, S22, S23, S42, S43</p> <p>1 = Blue / Blau / Bleu / Blu / Azul 2 = Yellow / Gelb / Jaune / Giallo / Amarillo 3 = Green / Grün / Vert / Verde / Verde 4 = Red / Rot / Rouge / Rosso / Rojo 5 = Black / Schwarz / Noir / Nero / Negro 6 = White / Weiß / Blanc / Bianco / Blanco  = Green/Yellow / Grün/Gelb / Vert/Jaune / Verde/Giallo / Verde/Amarillo</p>			 <p>Sipa S42 QD</p>	 <p>Sipa S43 QD</p>	 <p>Sipa S31 QD</p>

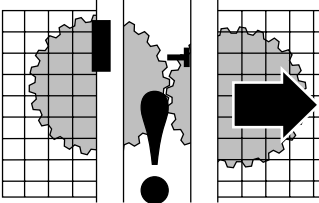
	<p>Check the machine is isolated and stopped whenever the interlocked guard door is open.</p> <p>IMPORTANT: After installation and commissioning, the actuator, switch and switch lid fixing screws should be coated with tamper evident varnish or similar compound.</p>	<p>Kontrollieren, dass die Maschine stets isoliert und angehalten wird, wenn die abhängigkeitsgeschaltete Schutzvorrichtungstür geöffnet wird.</p> <p>WICHTIG: Nach der Installation und Inbetriebnahme sind die Betätigungselement-, Schalter- und Schalterdeckel-Befestigungsschrauben mit manipulation-anzeigendem Lack oder einem ähnlichen Mittel zu versehen.</p>	<p>Vérifier que la machine est isolée et arrêtée chaque fois que la porte de sécurité est ouverte.</p> <p>IMPORTANT : Après l'installation et la mise en service, les vis de fixation de l'actionneur, du commutateur et de son couvercle doivent être enduites de vernis témoin ou d'un produit similaire.</p>	<p>Controllare che la macchina sia isolata ed in condizione di arresto ogni volta che la porta di protezione interbloccata sia aperta.</p> <p>IMPORTANTE: dopo l'installazione e la messa in servizio, l'attuatore, l'interruttore ed il coperchio dell'interruttore devono essere spalmati con vernice tamper evident o una sostanza simile.</p>	<p>Compruebe que la máquina esté parada y aislada siempre que la puerta de seguridad esté abierta.</p> <p>IMPORTANTE: Tras la instalación y la puesta en funcionamiento se deberá cubrir el accionador, el conmutador y los tonillos de sujeción de la tapa del conmutador con un barniz revelador de intentos de apertura o producto similar.</p>
--	--	--	--	--	---

<p>Maintenance Every Week Check the correct operation of the switching circuit. Also check for signs of abuse or tampering. Inspect the switch casing for damage.</p> <p>Repair If there is any malfunction or damage, no attempts at repair should be made. The unit should be replaced before machine operation is allowed. DO NOT DISMANTLE THE UNIT.</p>	<p>Wartung Jede Woche Auf ordnungsgemäße Funktion des Schaltkreises kontrollieren. Außerdem auf Anzeichen von Missbrauch oder Manipulation untersuchen. Schaltergehäuse & Welle auf Beschädigung kontrollieren.</p> <p>Reparatur Bei Fehlfunktion oder Beschädigung dürfen keine Reparaturversuche unternommen werden. Die Einheit muss ersetzt werden, bevor weiterer Betrieb der Maschine zugelassen wird. DIE EINHEIT DARF NICHT AUSEINANDERGEBAUT WERDEN.</p>	<p>Maintenance Toutes les semaines Vérifier le bon fonctionnement du circuit de commutation. Chercher également les signes d'un éventuel tripatouillage. Vérifier l'état du boîtier et de l'axe.</p> <p>Réparation En cas de défaut de fonctionnement ou d'endommagement, ne jamais essayer de réparer le dispositif. Il doit être remplacé avant de remettre la machine en service. NE JAMAIS DÉMONTER LE DISPOSITIF.</p>	<p>Manutenzione Ogni settimana Controllare che il circuito di commutazione funzioni come richiesto. Sincerarsi anche che non esistano indicazioni di un uso non autorizzato o di manomissioni. Esaminare l'involucro dell'interruttore e l'albero per verificare che non siano danneggiati.</p> <p>Riparazione In caso di funzionamento anomalo o di danno, non si deve cercare di effettuare una riparazione. L'unità deve essere sostituita prima di ricominciare a far funzionare la macchina. NON SMONTARE L'UNITÀ.</p>	<p>Mantenimiento Cada semana Compruebe que el circuito de conmutación funciona correctamente. Compruebe también que no haya signos de uso incorrecto o manipulación no autorizada. Compruebe que la carcasa y el eje no presenten daños.</p> <p>Reparación Si hubiera algún defecto o avería, no intente repararlos. Sustituya la unidad antes de autorizar el funcionamiento de la máquina. NO DESMONTE LA UNIDAD.</p>
---	--	---	--	--

CE
Declaration of Conformity
This is to declare that the products shown on this document conforms with the Essential Health and Safety Requirements (EHSR's) of the European Machinery Directive (98/37/EC), the relevant requirements of the Low Voltage Directive (73/23/EEC as amended by 93/68/EEC). These products also conform to EN 60947-5-1, EN 1088, EN 292, EN 60204-1 and have Third Party Approval.
For a comprehensive certificate please visit: www.ab.com/safety

CE
Konformitätserklärung
Hiermit wird bescheinigt, dass die auf diesem Dokument aufgeführten Produkte die grundlegenden Gesundheits- und Sicherheitsanforderungen (EHSR's) der Europäischen Maschinenrichtlinie (98/37/EC), die relevanten Anforderungen der Niederspannungsrichtlinie (73/23/EEC) gemäß Änderung durch 93/68/EEC erfüllen. Diese Produkte entsprechen auch EN 60947-5-1, EN 1088, EN 292, EN 60204-1 und sind für Dritte zugelassen.
Für ein ausführliches Zertifikat besuchen Sie bitte: www.ab.com/safety

CE
Déclaration de conformité
Nous déclarons par la présente que les produits mentionnés dans ce document sont conformes aux prescriptions essentielles d'hygiène et de sécurité de la directive européenne sur les machines (98/37/CEE), aux prescriptions pertinentes de la directive sur les basses tensions (73/23/CEE amendée par la directive 93/68/CEE). Ces produits sont également conformes aux normes EN 60947-5-1, EN 1088, EN 292, EN 60204-1 et bénéficient de l'homologation tierce partie.
Pour le certificat complet, consulter le site : www.ab.com/safety

CE
Dichiarazione di conformità
Con la presente si dichiara che i prodotti illustrati su questo documento sono conformi ai Requisiti essenziali per la salute e la sicurezza (EHSR) della Direttiva europea sui macchinari (98/37/CE), ai requisiti pertinenti della Direttiva per la bassa tensione (73/23/CEE come modificata da 93/68/CEE). Questi prodotti sono anche conformi alle normative EN 60947-5-1, EN 1088, EN 292, EN 60204-1 e sono approvati per un uso da parte di terzi.
Per visualizzare un certificato completo, si prega di visitare il sito: www.ab.com/safety

CE
Declaración de conformidad
Los productos que aparecen en este documento cumplen los requisitos esenciales de seguridad e higiene de la Directiva Europea de Maquinaria (98/37/EC) y los requisitos pertinentes de la Directiva de Bajo Voltaje (73/23/EEC, enmendada por 93/68/EEC). Asimismo, los productos cumplen la normativa EN 60947-5-1, EN 1088, EN 292, EN 60204-1 y cuentan con el sello Third Party Approval.
Para obtener toda la información acerca de seguridad, visite: www.ab.com/safety

Max. switching distance (safety)	S11, S12, S13 - make 5mm, break 11mm S21, S22, S23 - make 9mm, break 12mm S31 - make 5mm, break 12mm GD2 - make 10mm, break 13mm
Safety Contacts (auxiliary) S12, S22, S42 only S13, S23, S43 only	1 N.C. (black - white) not for safety use 1 N.O. (black - white) not for safety use
Operating Temperature Sipha GD2	-10 °C...+55 °C -25 °C...+125 °C
Mechanical Life	1 x 10 ⁶
Torque settings, Max.	1.0 N•m (8.85 lb•in) fixing bolts

Note: The safety contacts of these products are described as normally closed (N.C.), ie. with the guard closed, actuator in place (where relevant) and the machine able to be started.

Max. Schaltabstand (Sicherheit)	S11, S12, S13 - Schließen 5mm, Öffnen 11mm S21, S22, S23 - Schließen 9mm, Öffnen 12mm S31 - Schließen 5mm, Öffnen 12mm GD2 - Schließen 10mm, Öffnen 13mm
Sicherheitskontakte (Hilfs.) Nur S12, S22, S42 Nur S13, S23, S43	1 N.C. (schwarz - weiß) nicht für Sicherheitsbelegung 1 N.O. (schwarz - weiß) nicht für Sicherheitsbelegung
Betriebstemperatur Sipha GD2	-10 °C...+55 °C -25 °C...+125 °C
Mechanische Lebensdauer	1 x 10 ⁶
Drehmomenteinstellungen, Max.	1.0 N•m (8.85 lb•in) Befestigungsschrauben

Hinweis: Die Sicherheitskontakte dieser Produkte sind als normalerweise geschlossen (N.C.) beschrieben, d.h. bei geschlossener Schutzvorrichtung, Betätigungselement in Position (falls zutreffend) und Maschine startfähig.

Distance maxi. de commutation (sécurité)	S11, S12, S13 - fermeture 5mm, ouverture 11mm S21, S22, S23 - fermeture 9mm, ouverture 12mm S31 - fermeture 5mm, ouverture 12mm GD2 - fermeture 10mm, ouverture 13mm
Contacts de sécurité (auxiliaires) S12, S22, S42 only S13, S23, S43 only	1 NF (noir-blanc) ne pas utiliser pour la sécurité 1 NO (noir-blanc) ne pas utiliser pour la sécurité
Plage de températures de service Sipha GD2	-10 °C...+55 °C -25 °C...+125 °C
Durée de vie mécanique	1 x 10 ⁶
Couples de serrage	Vis de fixation 1.0 N•m

Remarque : Les contacts de sécurité de ces produits sont décrits comme normalement fermés (NF), c'est-à-dire lorsque la protection est fermée, l'actionneur en place (si applicable) et la machine en état de démarrer.

Distancia máxima de conmutación (seguridad)	S11, S12, S13 - apertura 5mm, cierre 11mm S21, S22, S23 - apertura 9mm, cierre 12mm S31 - apertura 5mm, cierre 12mm GD2 - apertura 10mm, cierre 13mm
Contactos de seguridad (auxiliares) S12, S22, S42 solamente S13, S23, S43 solamente	1 N.C. (negro - blanco) no se usa para seguridad 1 N.O. (negro - blanco) no se usa para seguridad
Temperatura operativa Sipha GD2	-10 °C...+55 °C -25 °C...+125 °C
Vida mecánica	1 x 10 ⁶
Ajustes de par, máx.	1.0 N•m (8.85 lb•in) tornillos de sujeción

Nota: Los contactos de seguridad de estos productos se describen como normalmente cerrados (o N.C.), es decir, con el protector cerrado, el accionador en su lugar (si procede) y la máquina en condiciones de arrancar.

Massima distanza di commutaz. (sicurezza)	S11, S12, S13 - chiusura 5mm, apertura 11mm S21, S22, S23 - chiusura 9mm, apertura 12mm S31 - chiusura 5mm, apertura 12mm GD2 - chiusura 10mm, break 13mm
Contatti di sicurezza (ausiliari) S12, S22, S42 only S13, S23, S43 only	1 NC (nero - bianco) non per scopi di sicurezza 1 NO (nero - bianco) non per scopi di sicurezza
Temperatura d'esercizio Sipha GD2	-10 °C...+55 °C -25 °C...+125 °C
Durata meccanica	1 x 10 ⁶
Regolazioni coppia, massima	1.0 N•m per i bulloni di fissaggio

NB: i contatti di sicurezza di questi prodotti sono descritti come normalmente chiusi (NC), vale a dire con la protezione chiusa, l'attuatore in funzione (ove sia richiesto) e la macchina in condizione di avviamento.