

# **Installation Instructions for North America**

*Point of Operation  
Control (POC)  
Safety Light Curtains*

## Important User Information

Because of the variety of uses for the products described in this publication, those responsible for the application and use of this control equipment must satisfy themselves that all necessary steps have been taken to assure that each application and use meets all performance and safety requirements, including any applicable laws, regulations, codes and standards.

The illustrations, charts, sample programs and layout examples shown in this guide are intended solely for purposes of example. Since there are many variables and requirements associated with any particular installation, Rockwell Automation Allen-Bradley does not assume responsibility or liability, including intellectual property liability for actual use based upon the examples shown in this publication.

### Related Safety Information

You are responsible for the safety of the entire installed control system and for meeting all applicable laws, codes, and safety requirements.



**ATTENTION:** As the installer of this control system, you must be knowledgeable of other applicable standards pertaining to safety recommendations related to:

- Machine Construction
- General Electrical
- Machine Guarding
- Point of Operation guards, safety light curtains, mechanical guards, and Two hand controls

In addition to local laws and codes, you are responsible for the safety recommendations detailed in all applicable codes and standards including:

- OSHA Regulations
  - ANSI Standards
  - NFPA
  - CSA
- 

### IMPORTANT

Rockwell Automation reserves the right to make revisions to these installation instructions and disclaims liability for all incidental and consequential damages related to the furnishing, performance and use of this material.

## Table of Contents

<b>Agency Approvals</b> .....	1
EU Europe .....	1
<b>Description</b> .....	3
Features .....	3
<b>Applications</b> .....	3
Areas of Application .....	3
Application Conditions .....	4
Corner Mirrors .....	4
<b>System Design</b> .....	5
<b>Theory of Operation</b> .....	5
Mode of Operation .....	5
Host/Guest Cascade (Daisy-Chaining) .....	5
<b>Installation</b> .....	5
General .....	5
US Safety Distance Formulas .....	6
OSHA Safety Distance Calculation Formula .....	6
The ANSI Safety Distance Formula .....	6
Safety Distance to Point of Operation .....	7
Mounting .....	7
Distance to Reflective Surfaces .....	7
Multiple Safety Systems per Application .....	8
Mechanical Installation .....	8
Electrical Installation .....	9
Test Input (Sender) .....	9
Outputs (Receiver) .....	9
RS-485 Communication Interface .....	10
<b>Specifications</b> .....	10
General .....	10
Weight of Systems .....	10
<b>Dimensions-mm (in)</b> .....	11
<b>Internal Connection Diagram</b> .....	11
Connection Diagram .....	13
<b>Selection of an Opto-Electronic Safety System</b> .....	14
Regulations .....	14
Corner Mirrors .....	14
Protected Height .....	14
Cascadable Systems (Guest/Host) .....	14
Accessories Selection Table .....	16
Corner Mirror Selection Table .....	16
<b>Diagnostics</b> .....	18
<b>Troubleshooting</b> .....	18

### Agency Approvals

#### EU Europe

TUV Rheinland  
AM Grauen Stein  
D-51105 Koin

#### BIA

Berufsgenossenschaftliches  
Institut für Arbeitssicherheit  
Alte Heerstrasse 111  
D-53757 St. Augustin

#### ISO 9001

#### USA

UL, cULus



### **ATTENTION!**

Failure to observe may result in dangerous operation

Throughout this manual we use the labels **ATTENTION** and **IMPORTANT** to alert you to the following:

**ATTENTION:** Identifies information about practices or circumstances that can lead to personal injury or death, property damage, or economic loss

**ATTENTION** helps you

- Identify a hazard
- Avoid a hazard
- Recognize the consequences

**IMPORTANT:** Identifies information that is especially important for successful application and understanding of the product.

All specifications subject to change

**IMPORTANT: Save these instructions for use at a future time.**

Generally recognized technical regulations and quality assurance system ISO 9000 are carefully applied during the development and production of Allen-Bradley/Guardmaster products.

This technical description must be followed when installing and commissioning the POC. Inspection and commissioning must be carried out by a qualified person.

## Conditions required for the proper installation and use of the POC Safety Light Curtain

Please make sure you read and understand these requirements before you select and install the POC Safety Light Curtain. POC Safety Light Curtains are point of operation safeguarding devices. These safety light curtains are intended to be used to provide point of operation safeguarding of personnel on a variety of machinery.

The POC family of safety light curtains are general purpose presence sensing devices which are designed to protect personnel working on or near machinery.

The installation of the POC Safety Light Curtain must comply with all applicable federal, state and local rules, regulations, and codes.

It is the responsibility of the employer to properly install, operate and maintain the product as well as the machinery on which the POC presence sensing device is installed.

POC Safety Light Curtains must be properly installed by qualified personnel.

POC Safety Light Curtains are presence devices and will not protect personnel from heat, chemicals or flying parts. They are intended to signal a stop of hazardous machine motion when the sensing field is broken.

POC Safety Light Curtains can only be used on machinery which can be stopped anywhere in its stroke or cycle.

POC Safety Light Curtains should never be used on full revolution clutched machinery.

The effectiveness of the POC safety light curtain is dependent upon the integrity of the machine control circuit. The machinery on which the POC presence sensing device is installed should have control circuitry that is fail safe in design.

All stopping mechanisms of the machinery should be inspected regularly to ensure proper operation. The protected machinery must have a consistent reliable and repeatable stopping time.



**ATTENTION:** Failure to read and follow these instructions can lead to misapplication or misuse of the POC Safety Light Curtain, resulting in personal injury and damage to equipment.

# Point of Operation Control Installation Instructions

## Description

Point of Operation Control (POC) safety light curtains are active opto-electronic protection devices (AOPD) with resolutions of 14mm (0.55in) or 30mm (1.18in).

Allen-Bradley/Guardmaster POC safety light curtains are self-checking AOPD and belong to Safety Category 4. They have been designed for industrial applications and are characterized by:

- High degree of reliability
- Maintenance-free components
- Practical size
- Sturdy modular construction
- Universal application possibilities
- Simple installation

## Features

Special features of the POC safety light curtain are:

- Low maintenance operation
- Control-reliable solid-state outputs
- State of the art microprocessor technology with custom-designed ASICs (Application Specific Integrated Circuits)
- Easy assembly and alignment
- Mini-style quick-disconnects
- Long scanning range and high resolution
- Small housing cross section: 52mm x 55mm (2.05in x 2.17in)
- Fast response time  $\leq 5$ ms
- Large excess gain
- Ability to daisy-chain two sensors (to prevent personnel from standing between protective field and the point of operation)
- Construction complies with IEC 61496 Category 4 (self-checking)
- Tested and approved for USA, Europe, Canada and Japan

Maximum scanning range	6m/18m (19.69ft/59.06ft)
Resolution (object sensitivity)	14mm/30mm (0.55in/1.18in)
Maximum height of protective field	1814mm/1832mm (71.4in/72.1in)
Minimum height of protective field	314mm/332 mm (12.36in/13.07in)
The optical axis (center of exit window) is marked on the end cap.	

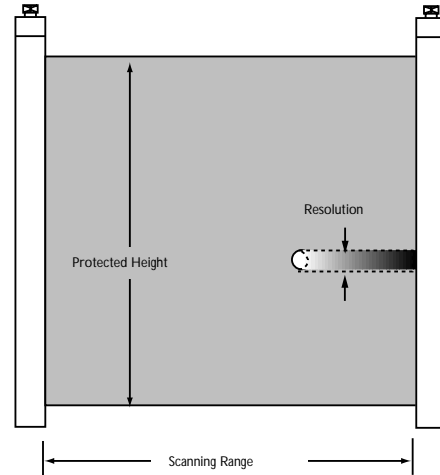

Figure 1  
Threshold values of a POC safety light curtain.

## Applications

### Areas of Application

POC safety light curtains can be used for point of operation (Figure 2), area (Figure 3), perimeter and entry/exit (Figure 4) safeguarding applications.

Typical areas of application are:

- Presses in the metal, plastics, rubber, leather and stone industries
- Punches in the leather, metal, textile and plastics processing industries
- Filter presses
- Trimming presses and cutters
- Processing machines and welding presses
- Assembly lines
- Revolving transfer machines
- Automatic assembly equipment
- Paper-cutting machines
- Robotic cells

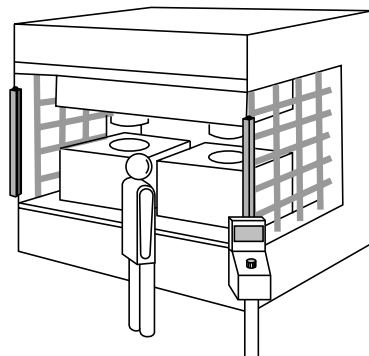

Figure 2  
Point of operation safeguarding with a POC safety light curtain.

# Point of Operation Control Installation Instructions

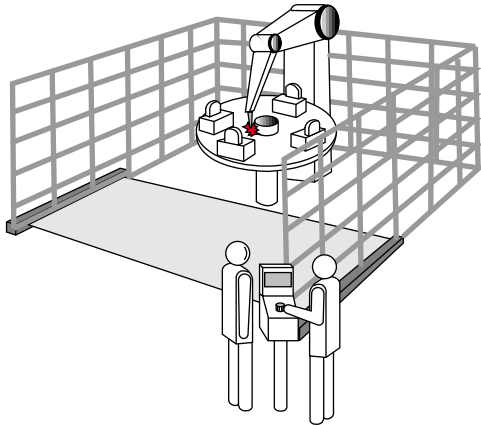

Figure 3  
Hazardous area safeguarding with a POC safety light curtain.

### Application Conditions

The machine or system control must be able to be stopped electrically. (The POC monitors the switching outputs for short circuits.)

You must be able to stop the hazardous machine motion consistently at any point in its stroke or cycle.

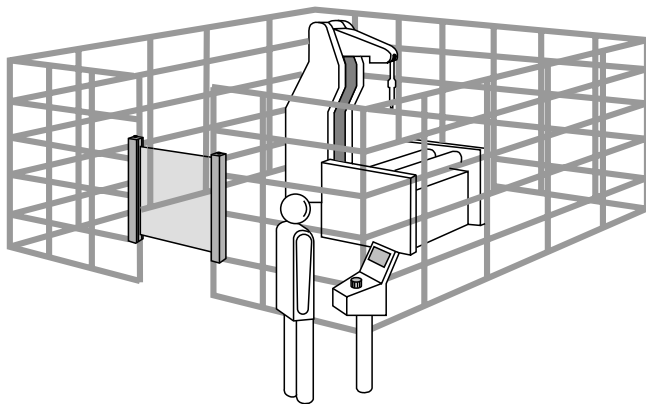

Figure 4  
Entry / exit safeguarding with a POC safety light curtain

The installation of the POC must adhere to the ANSI specification B11.19/E4.2.3.3.6, which states: "A presence sensing device shall prevent the operator or others from reasonably reaching over, around, under or through the sensing field into the hazardous area." Auxiliary safeguarding may be required in conjunction with the POC to accomplish this requirement (Figure 5).

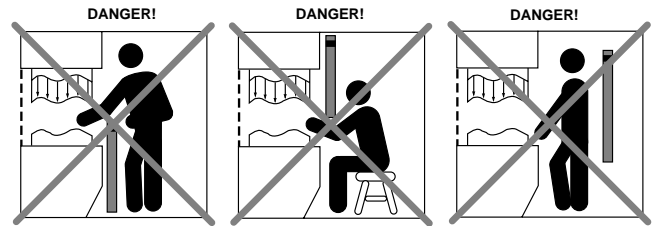
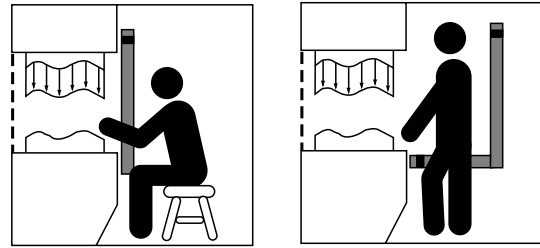

Figure 5  
The devices must be mounted so that the following are not possible: reaching over, reaching under and standing behind defensive fields.

Installation and operation must comply with all applicable regulations.

### Corner Mirrors

The protective field between the POC sender and the POC receiver can be bent around corners using corner mirrors (Figure 6). This allows the POC to safeguard multiple sides of a hazardous area or point of operation.

Note that each mirror reduces the total scanning range by approximately 10% per mirror.

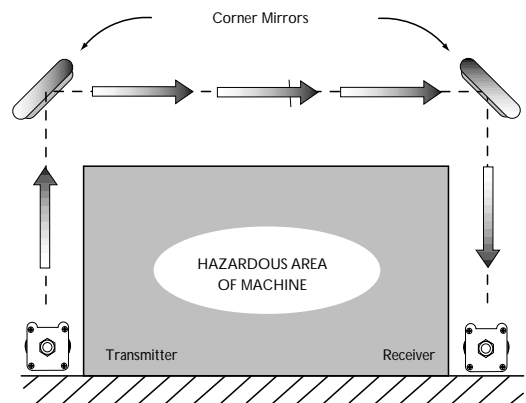

Figure 6  
Hazardous area safeguarding with the POC and a corner mirror.

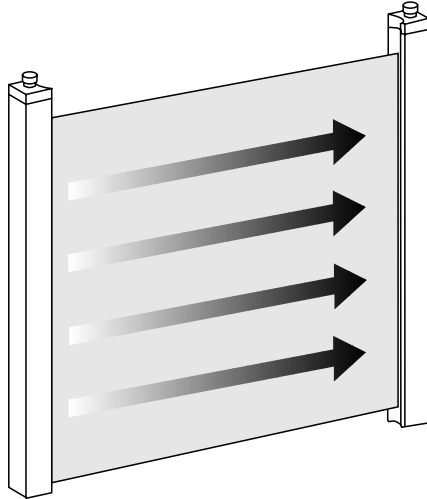

Figure 7  
The POC safety light curtain consists of sender and receiver with a protective field in between.

## System Design

The Allen-Bradley/Guardmaster POC safety light curtain consists of a sender and a receiver (Figure 7) with a protective field in between the protective field which is defined by the protected height and the scanning range.

The length of each system depends on the protected height required.

Synchronization between the sender and receiver is optical, i.e. an electrical connection between sender and receiver is not necessary.

The POC is a modular construction. All optical and electrical components are housed in one robust profile.

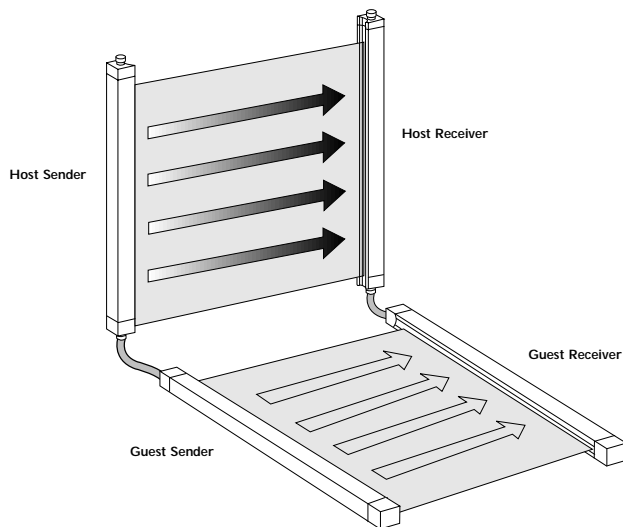

Figure 8  
Multiple plane sensing using the Host/Guest configuration.

## Theory of Operation

The infrared light pulses coded by the sender are sent to the receiver, which evaluates them. If an object, e.g. a finger or a hand ( $\geq 14\text{mm}/\geq 30\text{mm}$  ( $\geq 0.55\text{in}/\geq 1.18\text{in}$ )), penetrates the protective field, both outputs of the POC change state to stop the machine.

## Mode of Operation

The POC does not require a separate control unit or “third box” when operating in guard-only mode with manual restart. If other functions should be required, e.g. PSDI mode, blanking, muting, and others, the M8100 Series controller is available. The addition of the M8100 makes a wide variety of applications possible.

## Host/Guest Cascade (Daisy-Chaining)

In order to more effectively prevent someone from standing behind the sensing fields, an additional POC device can be connected in a daisy-chain configuration. Any desired combination is possible up to 240 beams. For example, a host 1200mm (47.2in) device with 14mm (0.55in) resolution for finger protection, could be connected to a guest 300mm (11.8in) device, with 30mm (1.18in) resolution to prevent someone from standing between the protective field and the point of operation. When using the **440L-M8100** with “mixed” daisy-chaining (e.g. host sensor with 14mm resolution with a guest sensor with 30mm resolution), the Dpf must be calculated using the larger (30mm) resolution.

When using the daisy-chain option, take note of the following:

- Maximum total number of beams is 240: 14mm (0.55in) resolution = 20 beams per every 150mm (5.91in) 30mm (1.18in) resolution = 10 beams per every 150mm
- Maximum cable length between Host/Guest devices: 170mm (6.7in) (shielded)
- Protected height increments: 150mm (5.91in), beginning with 300mm (11.8in)

Figure 8 shows one possible application. The guest sensor, unlike the main sensor, has no indicator lights. It is not designed to be used as a standalone device. The Host/Guest sensors with accessories are already prepared for daisy-chaining.

The maximum scanning range in mixed operation is 6m (19.7ft). The use of the M8100 controller is not permitted in mixed operation mode.

## Installation

### General

The POC can be used in most environments (IP 65). Safety distances as well as an adequate protected height must be observed. Pay special attention to the danger of personal reaching over, under, around, or standing behind sensing fields to reach the point of operation. This must be prevented mechanically or covered by another optical safety device (e.g. POC daisy-chaining).

## Point of Operation Control Installation Instructions

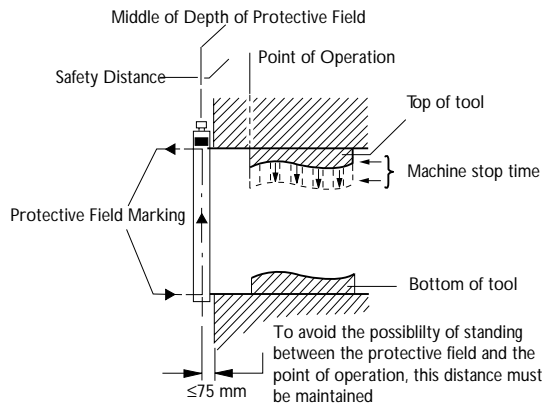

Figure 9  
Determining machine stopping time and safety distance.

### US Safety Distance Formulas



**ATTENTION!** The POC Safety Light Curtains must be mounted at a sufficient distance from the pinch point or point of operation hazard to ensure that the machine stops before a person's finger, hand, arm(s), or body reaches the hazard.

This distance, referred to as the safety distance, must be properly calculated prior to determining the safety light curtain protective height and mounting the light curtains on the machine. Failure to properly calculate this safety distance may result in operator injury.

**Note:** Regardless of the calculated safety distance, POC Safety Light Curtains should never be mounted closer than 6 inches from the point of operation or pinch point hazard.

In the United States there are two formulas that are used to properly calculate the safety distance. The first, the OSHA formula, is the minimum requirement for the calculation of the safety distance. The second formula, the one recommended by Rockwell Automation, is the ANSI formula, which incorporates additional factors to be considered when calculating the safety distance.

### OSHA Safety Distance Calculation Formula

The OSHA safety distance formula as specified in CFR Subpart O 1910.217 is as follows:

$$D_s = 63 \times T_s$$

- $D_s$  Safety Distance
- 63 Is the OSHA recommended hand speed constant in inches per second
- $T_s$  Is the total stop time of all devices in the safety circuit, measured in seconds. This value must include all components involved in stopping the hazardous motion of the machinery. For a mechanical power press it is the

stopping time measured at approximately the 90° position of the crankshaft rotation.

**Note:** The  $T_s$  number must include the response times of *all* devices, including the response time of the safety light curtain, the safety light curtain controller (if used), the machine's control circuit and any other devices that react to stop the hazardous motion of the machinery. Not including the response time of a device or devices in the stop time calculation will result in insufficient safety distance for the application. This may result in operator injury.

### The ANSI Safety Distance Formula

The ANSI safety distance formula, which is the Rockwell Automation recommended formula, is as follows:

$$D_s = K \times (T_s + T_c + T_r + T_{bm}) + D_{pf}$$

- $D_s$  Minimum safety distance between the safe guarding device and the nearest point of operation hazard, in inches.
- $K$  Hand speed constant in inches per second. The ANSI standard value is 63 inches per second when the operator begins reaching toward the point of operation hazard from rest. NOTE: ANSI B11.19 1990 E4.2.3.3.5 states "The value of the hand speed constant, K, has been determined by various studies and although these studies indicate speeds of 63 inches/second to over 100 inches/second, they are not conclusive determinations. The employer should consider all factors, including the physical ability of the operator, when determining the value of K to be used."
- $T_s$  Stop time of the machine tool measured at the final control element.
- $T_c$  Response time of the control system
- Note:**  $T_s$  and  $T_c$  are usually measured by a stop time measuring device.
- $T_r$  Response time of the presence sensing device (safety light curtain) and its interface, if any. This value is generally stated by the device manufacturer or it can be measured by the user.
- $T_{bm}$  Additional time allowed for the brake monitor to compensate for variations in normal stopping time.
- $D_{pf}$  Depth penetration factor. It is an added distance to allow for how far into the protective field an object, such as a finger or hand, can travel before being detected.  $D_{pf}$  is related to the safety light curtain's object sensitivity. Object sensitivity is the smallest diameter object which will always be detected anywhere in the sensing field.

## Safety Distance to Point of Operation



**ATTENTION!** The safety device requires a certain minimum distance between the sensor and the point of operation.

This ensures that the point of operation can be reached only after the hazardous motion has been stopped (Figure 9). The safety distance (according to EN 775, 999 and 294) is dependent on the following:

- Machine stop time
- Response time of the safety device
- Resolution of the safety device
- Hand speed

The following formula should be used when calculating the safety distance  $D_s$ :

$$D_s = K [T_s + T_c + T_r + T_{bm}] + D_{pf} \text{ or } D_s = K [\sum_{all}] + D_{pf}$$

$D_s$  = Minimum safety distance between device and the nearest point of operation hazard (in mm (inches)).

$K$  = Hand speed constant: 1600mm/sec or 63 in/sec.

$T_{all}$  = The sum of all stopping times.

$T_s$  = Stop time of the machine tool measured at the final control element (in seconds).

$T_c$  = Response time of the control system.

**Note:**  $T_s$  and  $T_c$  are usually measured by a stop-time measurement device and confirmed periodically.

$T_r$  = Response time of the presence-sensing safety device as stated on the product label.

$T_{bm}$  = Additional time allowed for the brake monitor to compensate for variations in normal stopping time (i.e. brake wear).

$D_{pf}$  = Added distance due to the depth of penetration factor. Can be obtained using the chart in Figure 10.

The minimum object sensitivity is stated on the product label. If beam blank-outs are used, this opening should be added to the object sensitivity.

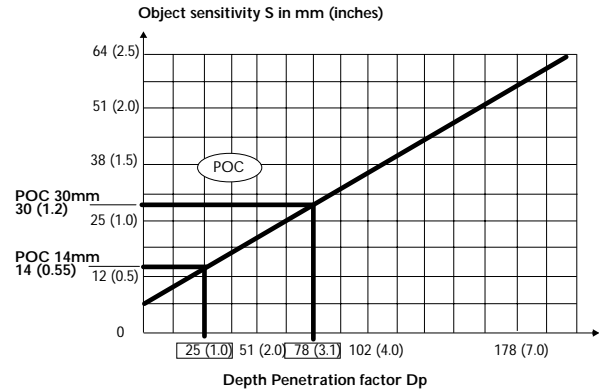

**NOTE 1-** This value will change if fixed blanking is used.

**NOTE 2-** Any object sensitivity greater than 63.5 (2.5) cannot reliably detect a person's hand or arm and should be considered a perimeter guard system.

Figure 10  
Depth penetration chart

## Mounting

After calculating the safety distance, the protective height must be determined. In making the determination of protective height, it is necessary to assure that a person can not access the point of operation hazard by reaching over, under or around the safety light curtain's protective field. It may be necessary to install mechanical guards in the areas between the safety light curtain and the equipment being guarded. It is the responsibility of the employer to assure that the point of operation hazard can only be accessed by passing through the protective field.

## Distance to Reflective Surfaces

Reflective surfaces that are present in the sensing field of the sender and receiver can cause reflections that may result in an object not being detected (Figure 11). Therefore, a minimum distance (a) must be kept from the reflective objects to the optical axis. The distance (a) is dependent on the distance between the sender and receiver unit, and on the alignment of the devices (Figure 12).

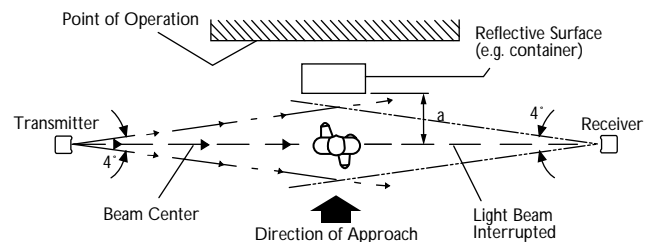

Figure 11  
Correct installation, correctly aligned. No optical short circuits. The object is already detected.

# Point of Operation Control Installation Instructions

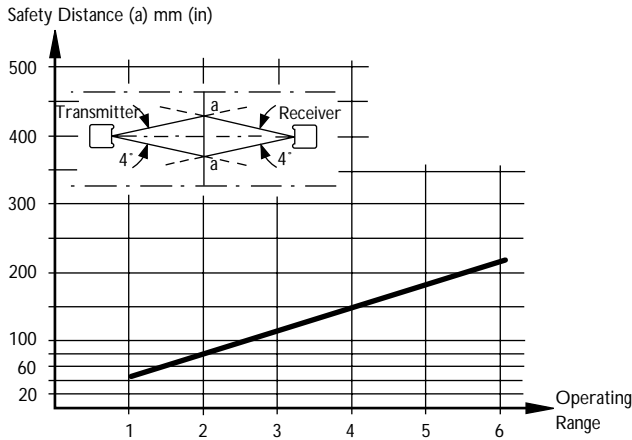

Figure 12  
Safety distance (a) relative to operating range.

## Multiple Safety Systems per Application

When using two POC systems per application, the systems should not be allowed to influence each other. As the distance between the transmitter and receiver increases, the light beams diverge and their cross sections become larger. This could result in the light beams being received by the wrong receiver. Light beams should be received only by their corresponding receiver. In order to rule out the possibility that receivers will receive light from the wrong sender devices, their alignment must be taken into consideration during installation (Figure 13).

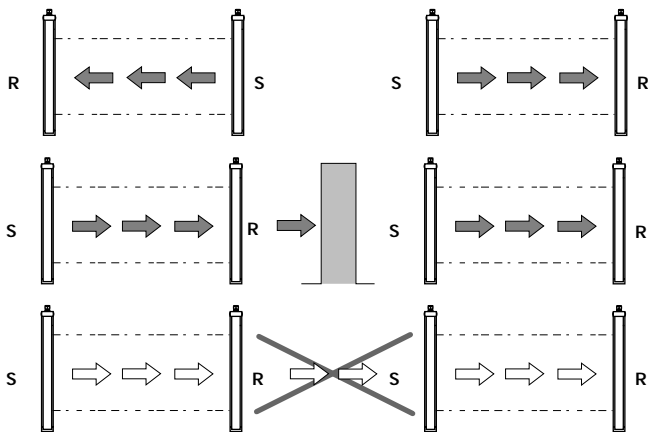

Figure 13  
Installing two POC systems next to each other (S = sender; R = receiver).

## Mechanical Installation

Fixed L-brackets, adjustable brackets and adjustable brackets with shock mounts are available for mounting the sender and receiver units (Figure 14). Fixed brackets can be used where no compensation for large mechanical tolerances is required. The adjustable brackets allow the sensors to be adjusted  $\pm 2^\circ$ .

## Dimensions—mm (in)

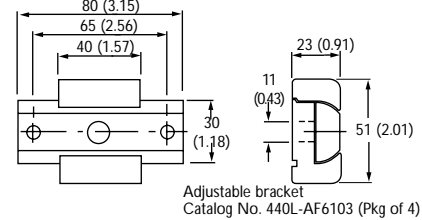
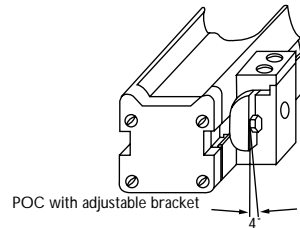
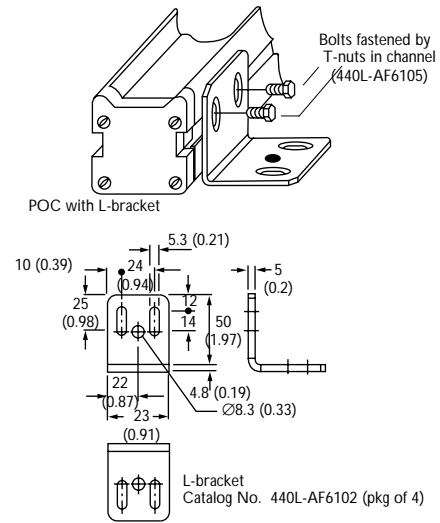

Figure 14  
POC mounting options: L-bracket, adjustable bracket and adjustable bracket with shock mount.

# Point of Operation Control Installation Instructions

Brackets with shock mounts can be used to reduce vibrations (e.g. on stamping presses). The brackets are attached to the sender and receiver using T-nuts. The T-nuts ride in grooves that run the full length of the light curtains on either side of the exit window. This allows for greater flexibility when mounting the light curtains.

## Electrical Installation

Cable lengths up to 60m (196.8ft) are permitted (over-voltage protection for level 3 and higher (IEG 801), see Technical Data). The sender is connected to the machine control using a 7-conductor cable (Figure 15), the receiver using a 7-conductor cable (Figure 17). The maximum wire cross section is 1.5mm (0.06in) without jacket; 1mm (0.04in) with jacket. All U.S. light curtains come standard with prewired mini style quick-disconnect in the end-caps. The POC requires +24V DC ( $\pm 20\%$ ) power supplies, which are available from Allen-Bradley/Guardmaster.

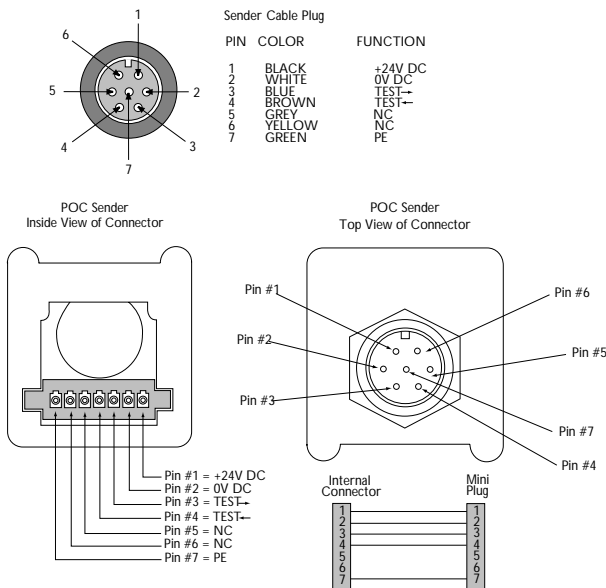

Figure 15  
POCS (sender) cable pin diagram

## Test Input (Sender)

The POC switches to the green condition after the supply voltage has been applied, and the automatic power-up test has been completed. If an external test is desired (Figure 16), a contact (normally closed) can be connected at the test input (MCC = Machine Control Contact). Minimum opening duration  $\geq 50\text{ms}$ .

Continuous current during closed test input: 12mA. In-rush current when closing: 150mA (20ms).

Test input open = Testing = Outputs on receiver inactive (red).

Test input closed = No test Outputs on receiver active (green).

The cable pin diagram for the sender is shown in Figure 15.

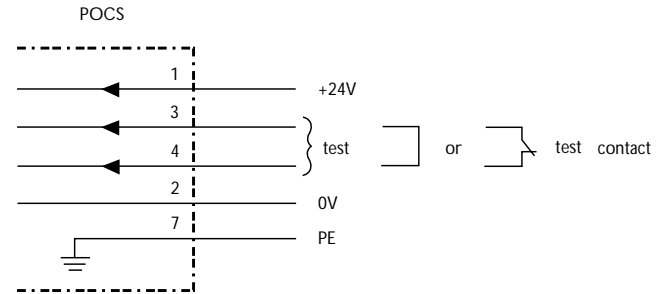

Figure 16  
POCS connection diagram

## Outputs (Receiver)

The output voltage  $U_A$  of each channel depends on the supply voltage  $U_V$  and the switched load and is at least

$$U_A = U_V - 2V$$

Both outputs OSSD1 and OSSD2 (OSSD = Output Signal Switching Device) are control reliable, actively monitored PNP solid state outputs. The outputs can carry a maximum of 0.5 Amps and are short circuit protected (Figure 18). If the protected field is clear, the two outputs are HIGH (active).

- An additional supply voltage must not be applied to the outputs.



**ATTENTION!** Both output signals must be processed separately. They must not be connected in series or parallel.

# Point of Operation Control Installation Instructions

## RS-485 Communication Interface

This interface serves to communicate with the **440L-M8100** (optional). If the **440L-M8100** is not used, the connection is not used.

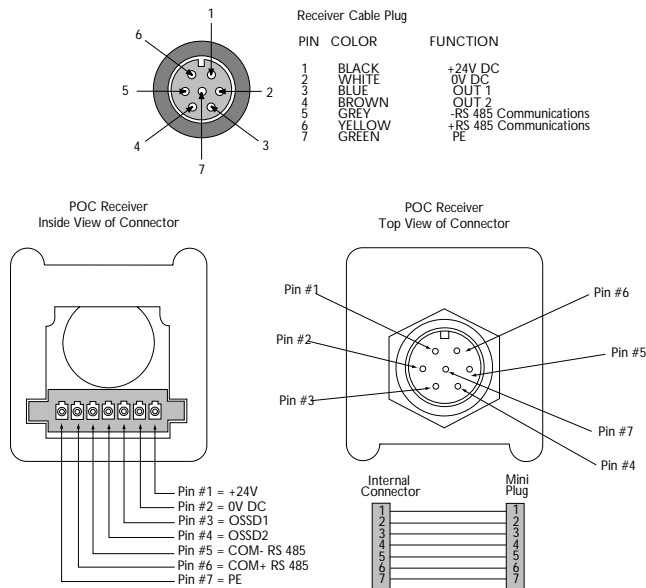

Figure 17  
Receiver cable pin diagram

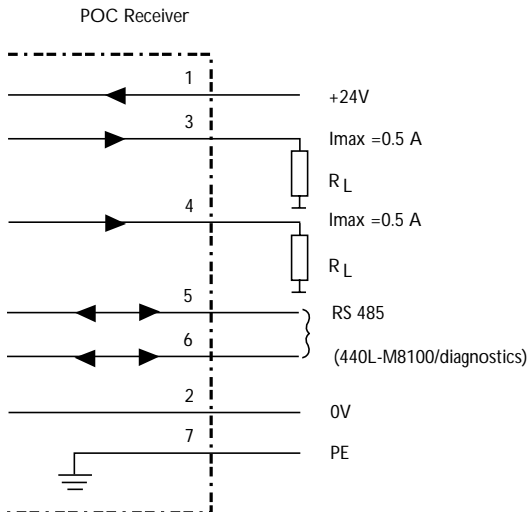

Figure 18  
Receiver connection diagram

## Specifications

### General

Protected Height	314mm...1832mm (12.3in...72.1in)
Scanning Range	0.3m...6m (0.98ft...19.6ft)/0.3m...18m (0.98ft...59.0ft)
Resolution	14mm/30mm (0.55in/1.18in)
Enclosure Rating	IP 65

Supply Voltage $U_v$	24V DC $\pm$ 20%
Maximum Residual Ripple	5 Vss
Power Consumption	0.9...1.5 Amps (no-load)
Synchronization	Optical, without separate synchronization channel
Outputs	2 x PNP, 0.5 A, short circuit protected
Minimum output voltage	$U_v - 2V$
Response Time	$\leq$ 5ms
Connection	Maximum wire cross section 1.0mm <sup>2</sup> with jacket 1.5mm <sup>2</sup> without jacket 60m (196.8ft) maximum Protection against over-voltage ( $\geq$ 1kV) from Level 3 or higher (IEC 801 part 5; 2 kV) between PE and +V.
Cable length	
Mode of Operation*	Guard-only with manual restart
Safety Category	Type 4 (self-checking)
Requirement	According to EN 50 100
Operating Ambient Temperature	0...55°C
Air Humidity	15%...95% (noncondensing)
Storage Temperature	-25...70°C
Dimensions	Length dependent upon protected height; (see dimensional drawings)
Height	
Housing cross section	52 mm x 55 mm

\*The POC without using a separate control unit, will operate in a guard only mode with manual restart.

## Weight of Systems

The values in the chart below are weights per system (Sender plus Receiver). Each component accounts for approximately 50% of the total weight. There is no difference in weight between the 14mm (0.55in) and 30mm (1.18in) versions of each model.

POC Model (mm)	Weight of System—kg (lbs)
300	2.8 (6.16)
450	4.0 (8.8)
600	5.0 (11)
750	6.0 (13.2)
900	7.0 (15.4)
1050	8.0 (17.6)
1200	9.2 (20.2)
1350	10.0 (22)
1500	11.2 (24.6)
1650	12.3 (27)
1800	13.4 (29.5)

# Point of Operation Control Installation Instructions

## Dimensions—mm (in)

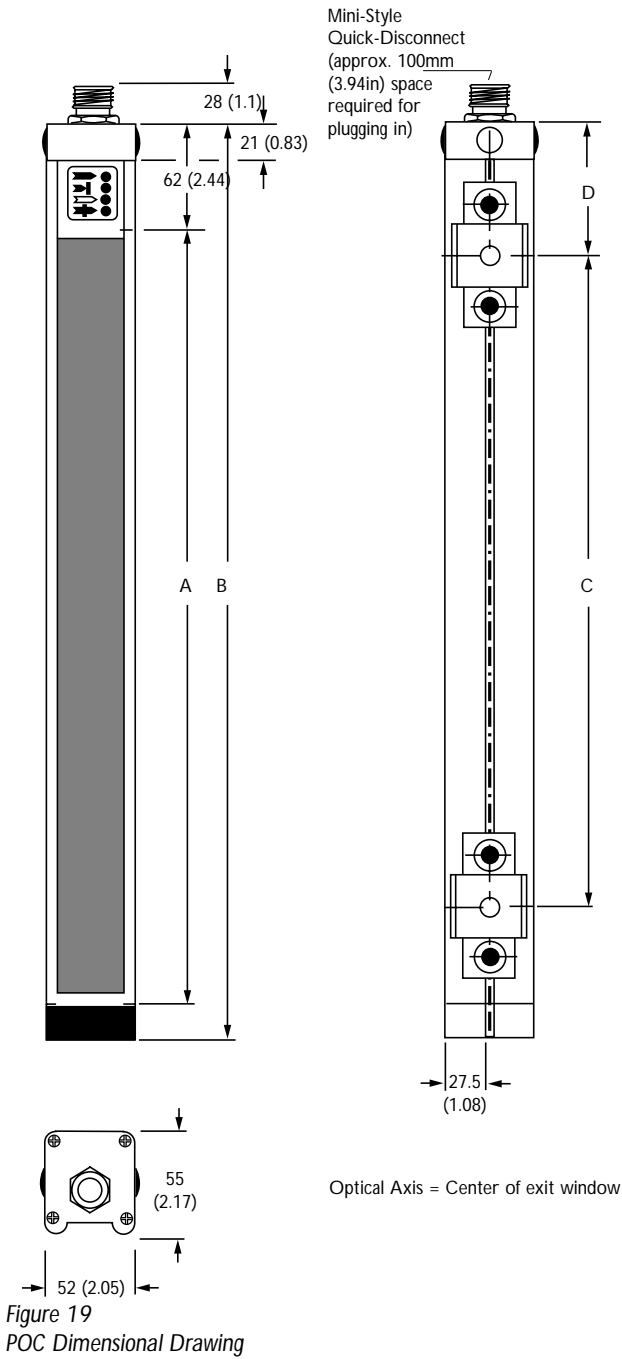

**NOTE:** Dimensions C & D represent the suggested distances of mounting brackets.

Protective Height	A	B	C	D
POC 300	300	384	224	80
POC 450	450	534	374	
POC 600	600	684	524	
POC 750	750	835	675	
POC 900	900	985	825	
POC 1050	1050	1135	975	
POC 1200	1200	1285	1125	
POC 1350	1350	1435	1275	
POC 1500	1500	1586	1426	
POC 1650	1650	1736	1576	
POC 1800	1800	1886	1726	

## Internal Connection Diagram

Figure 20 shows the pin connections for the POC terminal strip: left, sender; right, receiver.

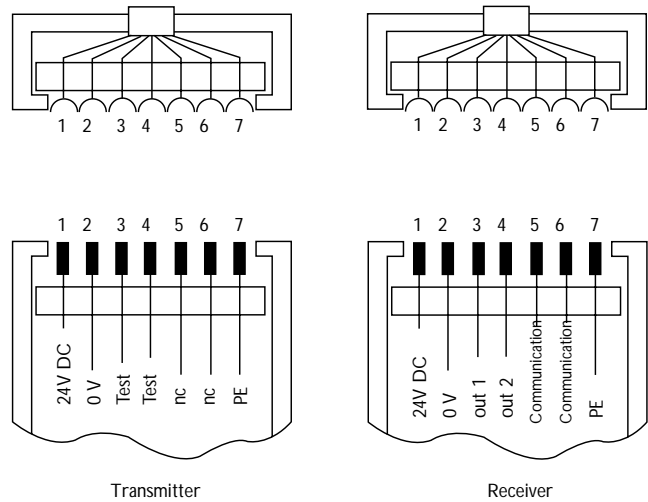
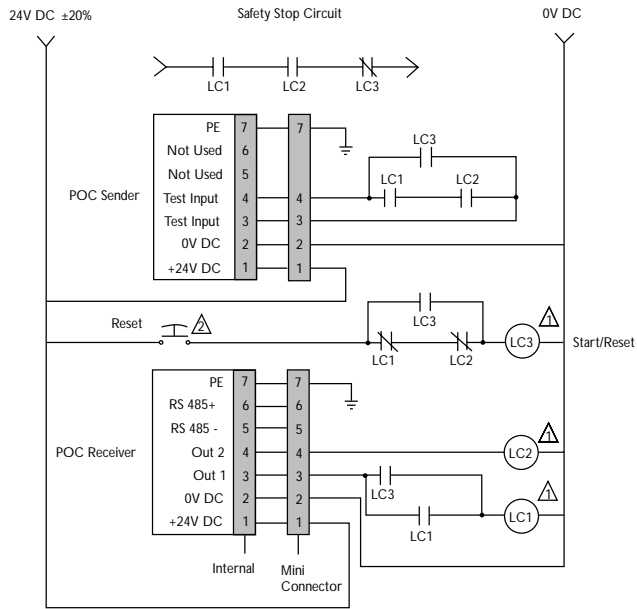

Figure 20  
Pin connections to mini-style quick-disconnect; left, sender; right, receiver.

# Point of Operation Control Installation Instructions



- ⚠ This interface is manual Start/Restart only. LC1, LC2 and LC3 must be captive contact safety relays.
- ⚠ Normally open momentary contact switch.

Figure 21  
POC with three relay interface

# Point of Operation Control Installation Instructions

## Connection Diagram

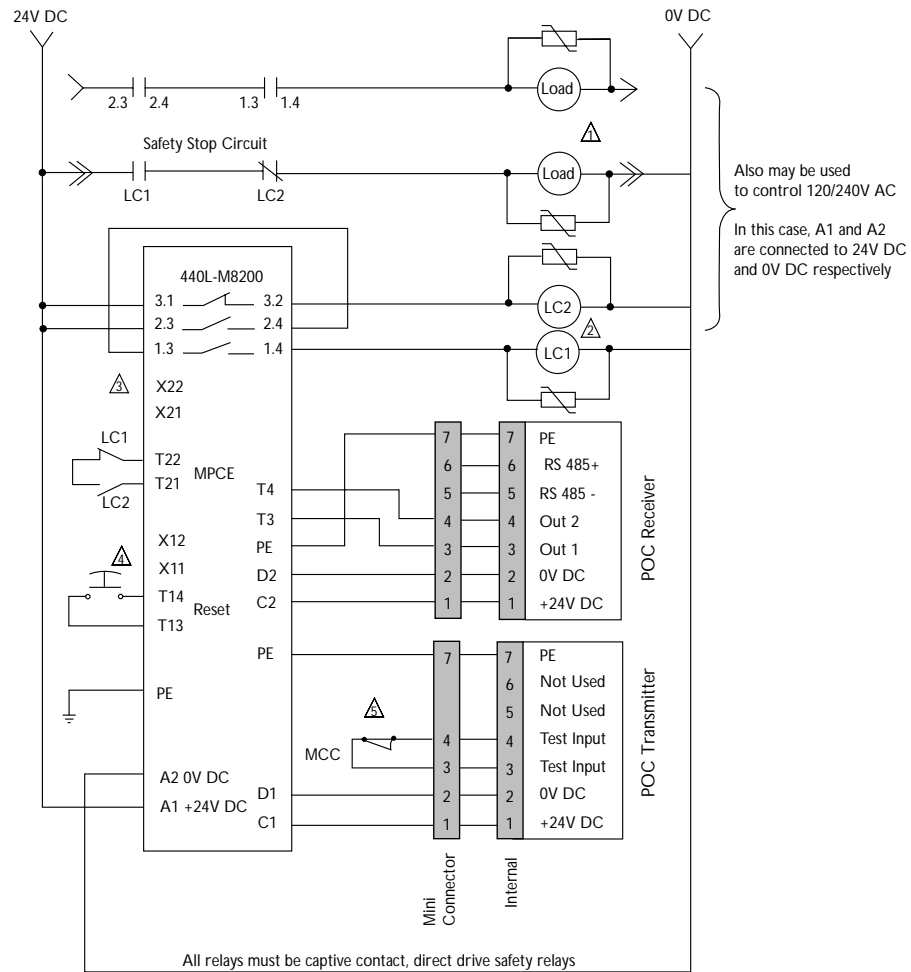

- 1 Loads such as: clutch breaks, servo motors, contactors, dual solenoid valves, etc.
- 2 Relays LC1 and LC2 are not required if load current is less than 4 Amps. In this case, the optional Safety Stop Circuit and "No External Contact Checking" should be used (see note 3).
- 3 For "No External Contact Check" jumper X21 to X22, leave T21 and T22 open; then use optional Safety Stop circuit as described in Note 2.
- 4 If "Automatic Reset" is allowed, remove the N.O. push button on T13 and T14 and jumper X11 to X12.
- 5 This circuit is jumpered for continuous operation machinery. If operator intervention is required this N.C. switch must be opened greater than 50ms during each nondangerous portion of the machinery cycle. (Please refer to OSHA regulations to determine if this is required.)

Figure 22  
Connection diagram 440L-M8200

## Point of Operation Control Installation Instructions

### Selection of an Opto-Electronic Safety System

In the selection of an opto-electronic safety device, consider the following elements:

#### Regulations

The appropriate OSHA and ANSI regulations must be adhered to when applying safety devices to machinery.

#### Corner Mirrors

Use of corner mirrors offers the possibility of safeguarding two or three sides.

Use of corner mirrors will also reduce the maximum sensing range 0.5m (1.64ft) per mirror.

#### Protected Height

Determine the required protected height for the application.

The protected height ensure that danger points are accessible only by going through the protective field.

#### Cascadable Systems (Guest/Host)

Host	
POC 14mm	POC 30mm
<b>Transmitter</b>	
440L-G4B0900-N	440L-G4D0900-N
440L-G4B1050-N	440L-G4D1050-N
440L-G4B1200-N	440L-G4D1200-N
440L-G4B1350-N	440L-G4D1350-N
440L-G4B1500-N	440L-G4D1500-N
<b>Receiver</b>	
440L-F4B0900-N	440L-F4D0900-N
440L-F4B1050-N	440L-F4D1050-N
440L-F4B1200-N	440L-F4D1200-N
440L-F4B1350-N	440L-F4D1350-N
440L-F4B1500-N	440L-F4D1500-N

Guest	
POC 14mm	POC 30mm
<b>Transmitter</b>	
440L-E4B0150-N	440L-E4D0150-N
440L-E4B0300-N	440L-E4D0300-N
440L-E4B0450-N	440L-E4D0450-N
440L-E4B0600-N	440L-E4D0600-N
440L-E4B0750-N	440L-E4D0750-N
440L-E4B0900-N	440L-E4D0900-N
<b>Receiver</b>	
440L-D4B0150-N	440L-D4D0150-N
440L-D4B0300-N	440L-D4D0300-N
440L-D4B0450-N	440L-D4D0450-N
440L-D4B0600-N	440L-D4D0600-N
440L-D4B0750-N	440L-D4D0750-N
440L-D4B0900-N	440L-D4D0900-N

Host Pairs	
POC 14mm	POC 30mm
440L-C4B0900-N	440L-C4D0900-N
440L-C4B1050-N	440L-C4D1050-N
440L-C4B1200-N	440L-C4D1200-N
440L-C4B1350-N	440L-C4D1350-N
440L-C4B1500-N	440L-C4D1500-N

Guest Pairs	
POC 14mm	POC 30mm
440L-B4B0150-N	440L-B4D0150-N
440L-B4B0300-N	440L-B4D0300-N
440L-B4B0450-N	440L-B4D0450-N
440L-B4B0600-N	440L-B4D0600-N
440L-B4B0750-N	440L-B4D0750-N
440L-B4B0900-N	440L-B4D0900-N

When cascading, please note:

- Maximum total beam number is 240.
- Maximum length of flexible cable between two cascaded devices is 170 mm (shielded).

The host sensor is provided with a quick-disconnect plug for cascading and the guest sensor with its cable and cable receptacle is ready for connection (length of flexible cable is 170 mm).

# Point of Operation Control Installation Instructions

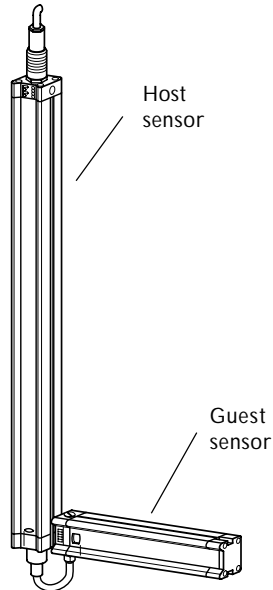
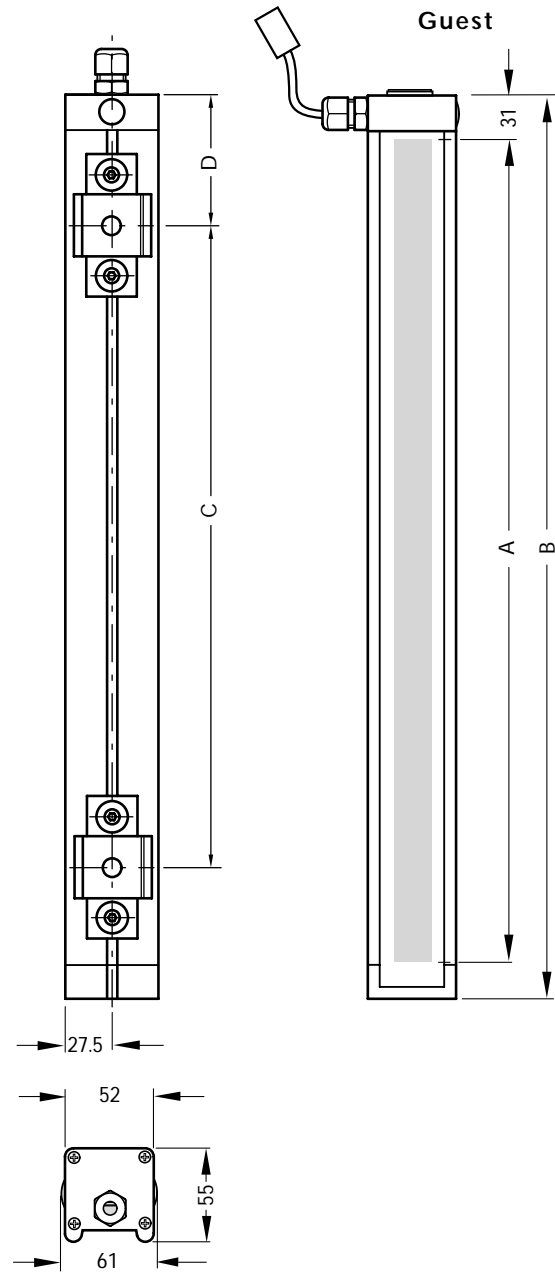

Figure 23 Interconnection of host and guest sensors



## Guest

	A	B	C	D
150	150	200		
300	300	350	190	80
600	600	650	490	80
750	750	800	640	80
900	900	950	790	80

Other sizes available on request

Figure 24 Guest POC dimensional drawing

# Point of Operation Control Installation Instructions

POC Selection Table

Resolution mm	Protected Height		Catalog Number
	mm	in	
14	314	12.3	440L-T4B0300-N
			440L-R4B0300-N
30	332	13.0	440L-T4D0300-N
			440L-R4D0300-N
14	464	18.2	440L-T4B0450-N
			440L-R4B0450-N
30	482	18.9	440L-T4D0450-N
			440L-R4D0450-N
14	614	24.1	440L-T4B0600-N
			440L-R4B0600-N
30	632	24.8	440L-T4D0600-N
			440L-R4D0600-N
14	764	30.0	440L-T4B0750-N
			440L-R4B0750-N
30	782	30.8	440L-T4D0750-N
			440L-R4D0750-N
14	914	36.0	440L-T4B0900-N
			440L-R4B0900-N
30	932	36.7	440L-T4D0900-N
			440L-R4D0900-N
14	1064	41.9	440L-T4B1050-N
			440L-R4B1050-N
30	1082	42.6	440L-T4D1050-N
			440L-R4D1050-N
14	1214	47.8	440L-T4B1200-N
			440L-R4B1200-N
30	1232	48.5	440L-T4D1200-N
			440L-R4D1200-N
14	1364	53.7	440L-T4B1350-N
			440L-R4B1350-N
30	1382	54.4	440L-T4D1350-N
			440L-R4D1350-N
14	1514	59.6	440L-T4B1500-N
			440L-R4B1500-N
30	1532	60.3	440L-T4D1500-N
			440L-R4D1500-N
14	1664	65.5	440L-T4B1650-N
			440L-R4B1650-N
30	1682	66.2	440L-T4D1650-N
			440L-R4D1650-N
14	1814	71.4	440L-T4B1800-N
			440L-R4B1800-N
30	1832	72.1	440L-T4D1800-N
			440L-R4D1800-N

Accessories Selection Table

Products	Catalog Number
L-Mounting bracket, fixed	440L-AF6102
Mounting bracket, adjustable	440L-AF6103
Mounting bracket, adjustable with shock mount	440L-AF6104 4 required per system
Safety Interface Control Module 120V Relay Module 24V DC Relay Module	440L-M8100 440L-M8300 440L-M8200
Laser alignment aid POC adaptor for alignment aid	440L-ALAT 440L-ALBRK
4 sliding nuts as spare parts (4 nuts delivered as standard)	440L-AF6105
Power Supply Module Input power: 120V AC/230V AC Voltage range: 85-265V AC Output: 24V DC Range: 20.4 to 27.6V DC 3.0 amps	1794-PS3

Corner Mirror Selection Table

Specially constructed mirrors for 2 and 3 sided safeguarding applications.

**NOTE:** Each mirror reduces scan range by 10% per mirror.

For POC Models	ML	OL	CH	Catalog Number
300	17.016	17.354	N/A	440L-AMIRR0300
450	23.609	23.889	N/A	440L-AMIRR0450
600	30.188	30.464	N/A	440L-AMIRR0600
750	36.656	37.000	N/A	440L-AMIRR0750
900	43.188	43.535	N/A	440L-AMIRR0900
1050	46.453	46.803	N/A	440L-AMIRR1050
1200	53.031	53.377	26.689	440L-AMIRR1200
1350	62.844	63.181	31.591	440L-AMIRR1350
1500	68.859	69.204	34.602	440L-AMIRR1500
1650 or 1800	75.931	75.740	37.870	440L-AMIRR1800

\* Mounting kit for mirrors. Each kit contains 1 bracket with fasteners. Order 2 kits per mirror.

# Point of Operation Control Installation Instructions

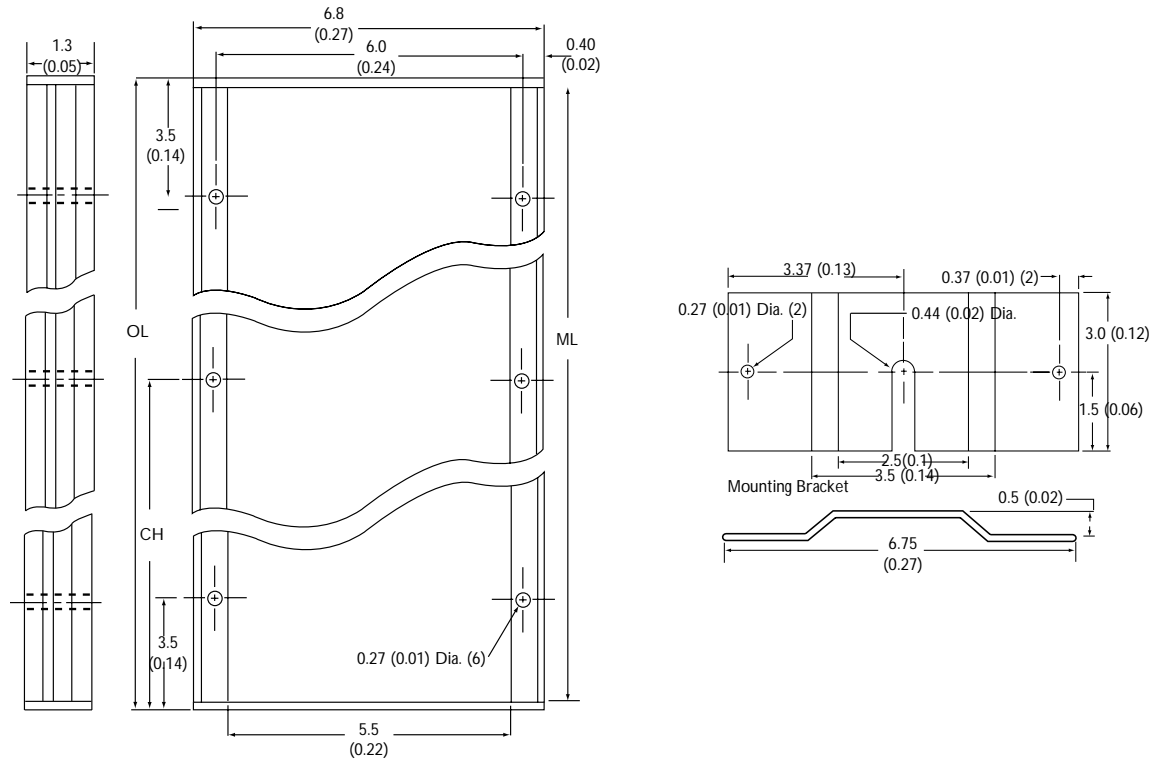

Figure 25  
Dimensions of corner mirrors and mounting brackets—mm (in)

# Point of Operation Control Installation Instructions

## Diagnostics

### Troubleshooting

Troubleshooting can be done through the use of the LED indicators positioned on both the sender and the receiver. Figure 26 shows the function of the indicator LEDs on the POC.

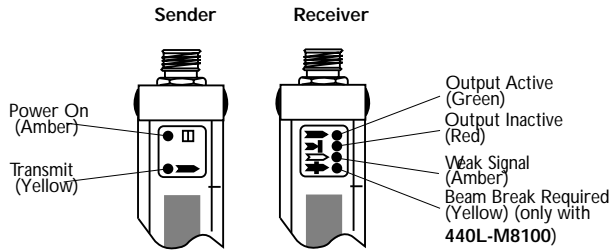

Figure 26  
The LEDs on the sender and receiver of the POC.

### Diagnostics Table

	Appearance	Identification	Action/Checks
Sender	Amber LED off Yellow LED off	Supply voltage	-Supply voltage and wire connections -Replace sender control board or sender
	Amber LED on Yellow LED off	Sender not emitting infrared light	-Test input open, check wires 3 and 4 on sender -Replace sender control board or sender
	Amber LED on Yellow LED on	Sender is emitting infrared light	-Sender is transmitting
Receiver	No LED lights	Supply voltage	-Supply voltage and wire connections -Replace receiver control board or receiver
	Red LED on	Obstruction	-Look for any objects protruding into protective field
	Red LED on without beam break	Sender test input open or sender not emitting infrared light	-Restart required -Test input open, check wires 3 and 4 on sender -Replace sender control board or sender
		System out of alignment	-Adjust both curtains side to side -Make sure curtains are plum and at the same level
	Weak signal indicator is permanently lit	Dirt build up sender or receiver	-Clean exit windows -Alignment
	Red LED on Amber LED, 2 blinks & a pause	Sender or alignment	-Test input open, check wires 3 and 4 on sender -Alignment -Replace sender control board or sender
	Red LED on Amber LED, 3 blinks & a pause	Receiver	-Alignment -Test input open, check wires 3 and 4 on sender -Replace receiver control board or receiver
	2 or more LEDs are blinking constantly	System in "lockout"	-Check for proper power by verifying proper DC input voltage -Verify there is no AC or DC voltage between 0V and PE -Verify OSSDs are not shorted to each other, 24V DC or 0V -Replace receiver control board or receiver
Green LED on	System okay	-Light curtains synchronized with no obstruction	





Please contact us for Technical Assistance:

In the U.S.: 1-800-666-0001

Outside U.S.: 001-978-441-9500

On line: <http://www.ab.com/safety>

**Reach us now at [www.rockwellautomation.com](http://www.rockwellautomation.com)**

Wherever you need us, Rockwell Automation brings together leading brands in industrial automation including Allen-Bradley controls, Reliance Electric power transmission products, Dodge mechanical power transmission components, and Rockwell Software. Rockwell Automation's unique, flexible approach to helping customers achieve a competitive advantage is supported by thousands of authorized partners, distributors and system integrators around the world.

**Americas Headquarters**, 1201 South Second Street, Milwaukee, WI 53204, USA, Tel: (1) 414 382-2000, Fax: (1) 414 382-4444  
**European Headquarters SA/NV**, avenue Herrmann Debroux, 46, 1160 Brussels, Belgium, Tel: (32) 2 663 06 00, Fax: (32) 2 663 06 40  
**Asia Pacific Headquarters**, 27/F Citicorp Centre, 18 Whitfield Road, Causeway Bay, Hong Kong, Tel: (852) 2887 4788, Fax: (852) 2508 1846



**Rockwell Automation**