

- According to EU directive for machines 98/37/EG
- According to IEC 204-1, EN 60 204-1, DIN VDE 0113-1, EN 954-1
- Safety category 4 according to DIN EN 954-1
- Output: max. 2N/O + 1N/C contacts, see contacts
- Single and 2-channel operation
- Monitoring of Reset-button function
- Manual reset or automatic reset when connecting the supply voltage, switch S2
- Option: fast auto start
- LED indicator for state of operation
- LED indicator for channel 1 and 2
- Removable terminal strips
- Wire connection: also 2 x 1,5 mm² stranded ferruled (isolated), DIN 46 228-4 or 2 x 2,5 mm² stranded ferruled DIN 46 228-1/-2/-3
- Width 22,5 mm

Function diagram

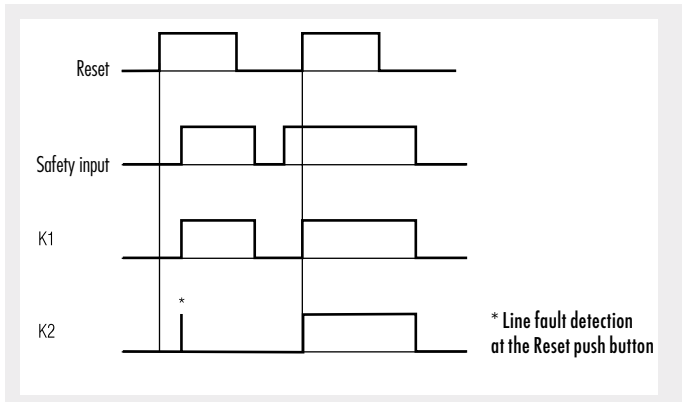

Approvals and marking



Applications

Protection of people and machines
 • control unit for light curtains with selftest according to DIN EN 61496-1.

Indicators

upper LED: on when supply connected
 lower LEDs: on when relay K1 and K2 energized

Notes

Monitoring of Reset-button function:
 Monitoring of Reset-button function is only active when S12 and S22 are switched simultaneously. If the Reset-button is closed before S12, S22 is connected to voltage (also when fault across Reset-Button), the output contacts will not close.
 A fault across the Reset-button which occurred after activation of the relay, will be detected with the next activation and the output contacts will not close. If a fault occurs after the voltage has been connected to S12, S22, the unit will be activated because this fault is similar to the normal Reset-function. The gold plated contacts of the MSR21L mean that this module is also suitable for switching small loads of 1 mVA - 7 VA, 1 mW - 7 W in the range 0,1 - 60 V, 1 - 300 mA. The contacts also permit the maximum switching current. However since the gold plating will be burnt off at this current level, the device is no longer suitable for switching small loads after this.

Block diagram

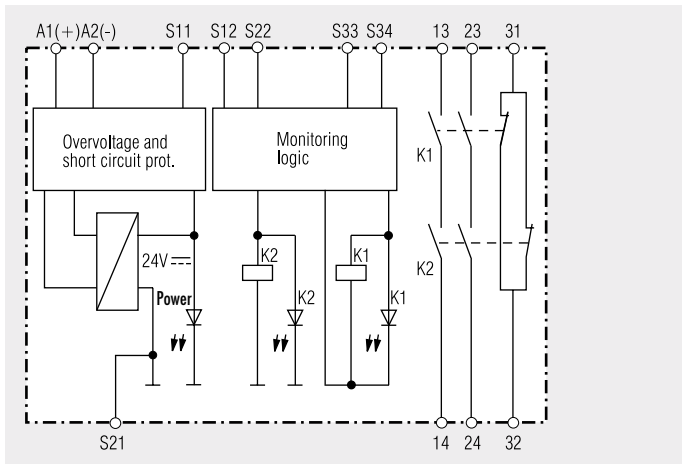

Circuit diagrams

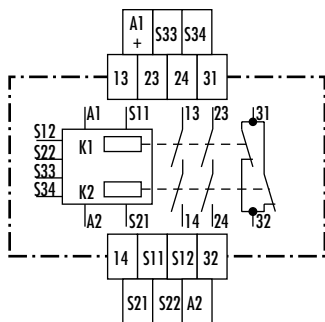

Unit programming



Isolate power before removing cover

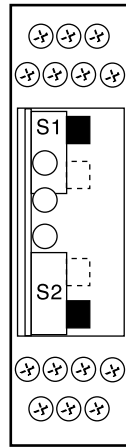
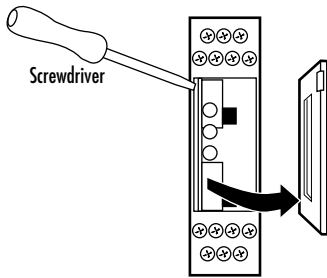

Drawing shows setting at the state of delivery

Switch S1

Upper position for Light Curtains with symmetric outputs, (both outputs switch positive signal).
Lower position for Light Curtains with asymmetric outputs, (1 output switches positive signal, 1 output switches negative signal).

Switch S2

Upper position for Auto reset.
Lower position for Manual reset.

On light curtains with asymmetric outputs the positive switching output has to be connected to S12 and the negative switching output connected to S22. External wiring remains the same.

Technical data

Input circuit

| | |
|--|------------------------------|
| Nominal Voltage U_N: | DC 24 V |
| Voltage range | DC |
| at 10% residual ripple: | 0,9 ... 1,1 U_N |
| Nominal consumption: | DC approx. 2 W |
| Min. Off-time: | 250 ms |
| Control voltage on S11: | DC 23 V at U_N |
| Control current over S12, S22: | 40 mA at U_N |
| Min. voltage on S12, S22: | DC 21 V when relay activated |
| Short-circuit protection: | Internal PTC |
| Overvoltage protection: | Internal VDR |

Output

| | | |
|--|---|---------------|
| Contacts | MSR21L 2 N/O safety + 1 N/C aux contacts | |
| Operate delay typ. at U_N: | Manual start: 40 ms automatic start: 250 ms | |
| Release delay typ. at U_N: | Disconnecting the supply: 50 ms De-energising S12, S22: 15 ms | |
| Contact type: | positive guided | |
| Nominal output voltage: | AC 250 V DC: see limit curve for arc-free operation | |
| Switching of low loads: | (contact 5 Au) ≥ 100 mV ≥ 1 mA | |
| Thermal current I_{th}: | on 1 contact path: see current limit curve on more than 1 contact path: max. 8 A | |
| Switching capacity | to AC 15: max. 7 A per contact path | |
| | AC 3 A / 230 V | EN 60 947-5-1 |
| | for NO contacts | |
| | AC 2 A / 230 V | EN 60 947-5-1 |
| | for NC contact | |
| Electrical contact life | to AC 15 at 2 A, AC 230 V: 10^5 switching cycles EN 60 947-5-1 | |
| Permissible operating frequency: | max. 1 200 operating cycles / h | |
| Short circuit strength | max. fuse rating: 6 A general-purpose EN 60 947-5-1 line circuit breaker: C 8 A | |
| Mechanical life: | 10 x 10^6 switching cycles | |

Technical data

General data

| | | |
|---|---|--|
| Operating mode: | Continuous operation | |
| Temperature range: | -15°C ... +55°C | |
| Clearance and creepage distances | Overvoltage category / contamination level: 4 kV / 2 DIN VDE 0110-1 (04.97) | |
| EMC | Electrostatic discharge: 8 kV (air) EN 61 000-4-2 HF irradiation: 10 V / m EN 61 000-4-3 Fast transients: 2 kV EN 61 000-4-4 Surge voltages between wires for power supply: 1 kV EN 61 000-4-5 between wire and ground: 2 kV EN 61 000-4-5 Interference suppression: Limit value class B EN 55 011 | |
| Degree of protection: | Housing: IP 40 EN 60 529 Terminals: IP 20 EN 60 529 | |
| Housing: | Thermoplastic with V0 rating according to UL subject 94 | |
| Vibration resistance: | Amplitude 0,35 mm EN 60 068-2-6 frequency 10 ... 55 Hz | |
| Climate resistance: | 15 / 055 / 04 EN 60 068-1 | |
| Terminal designation: | EN 50 005 | |
| Wire connection: | 1 x 4 mm ² solid or 1 x 2,5 mm ² stranded ferruled (isolated) or 2 x 1,5 mm ² stranded ferruled (isolated) DIN 46 228-1/-2/-3/-4 or 2 x 2,5 mm ² stranded ferruled DIN 46 228-1/-2/-3 | |
| Wire connections: | Box terminal with wire protection, removable terminal strips | |
| Mounting: | DIN rail EN 50 022 | |
| Weight: | 220 g | |

Dimensions

Width x height x depth: 22,5 x 84 x 118 mm

Characteristics

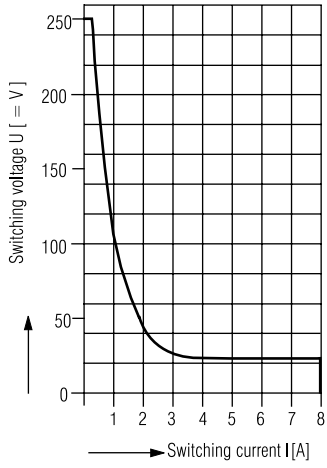

----- safe braking, no continuous arcing
max 1 switching cycle/s

Arc limit curve under resistive load

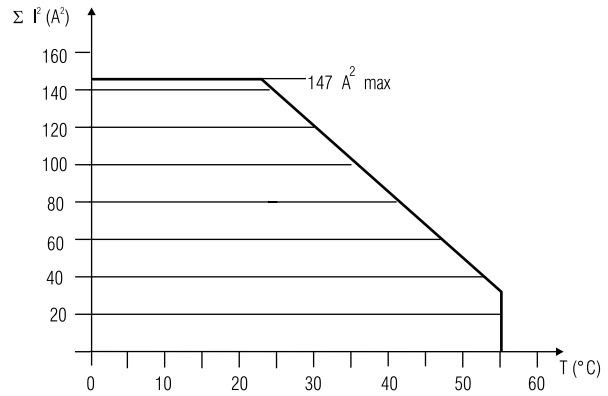

Quadratic total current limit curve

Application example

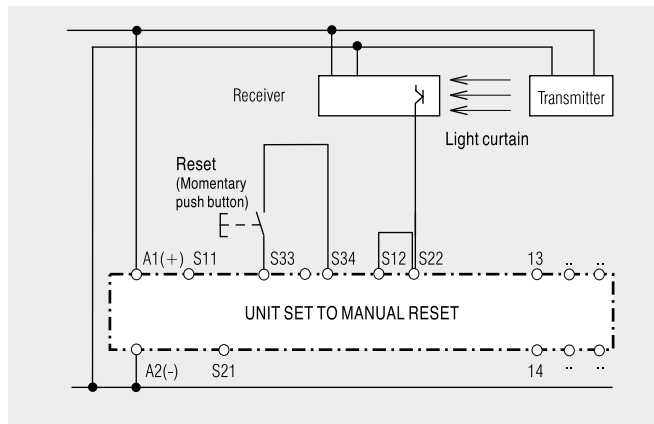

1-channel control by light curtain with selftest

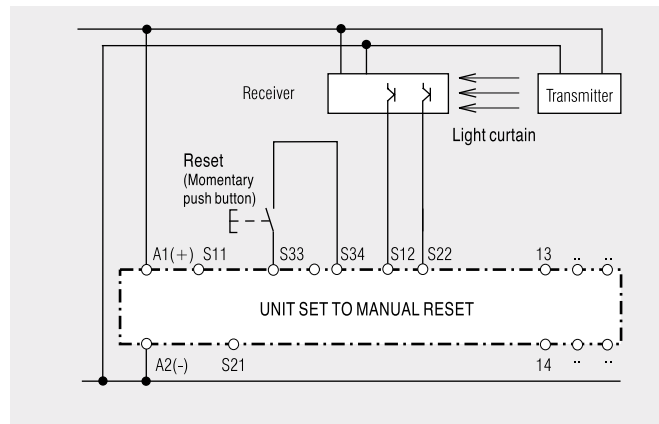

2-channel control by light curtain with self test.

Dual channel monitoring by light curtain.

On light curtains with asymmetric outputs the positive switching output has to be connected to S12 and the negative switching output connected to S22. External wiring remains the same.

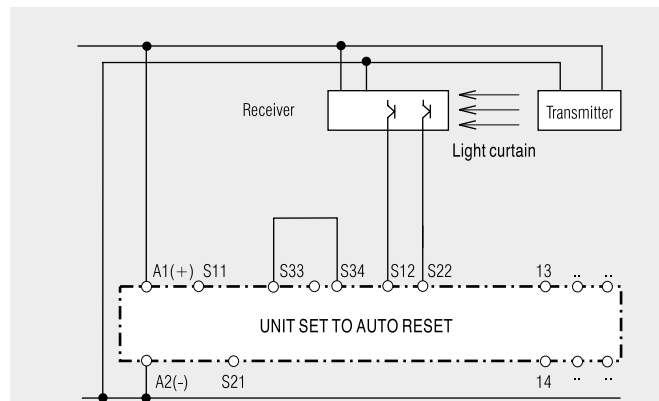

2-channel control by light curtain with self test.

Dual channel monitoring by light curtain.

On light curtains with asymmetric outputs the positive switching output has to be connected to S12 and the negative switching output connected to S22. External wiring remains the same.

