



Installation Instructions for North America

*Area Access Control (AAC)
Safety Single Beam*

Important User Information

Because of the variety of uses for the products described in this publication, those responsible for the application and use of this control equipment must satisfy themselves that all necessary steps have been taken to assure that each application and use meets all performance and safety requirements, including any applicable laws, regulations, codes and standards.

The illustrations, charts, sample programs and layout examples shown in this guide are intended solely for purposes of example. Since there are many variables and requirements associated with any particular installation, Rockwell Automation Allen-Bradley does not assume responsibility or liability, including intellectual property liability for actual use based upon the examples shown in this publication.

Related Safety Information

You are responsible for the safety of the entire installed control system and for meeting all applicable laws, codes, and safety requirements.



ATTENTION: As the installer of this control system, you must be knowledgeable of other applicable standards pertaining to safety recommendations related to:

- Machine Construction
- General Electrical
- Machine Guarding
- Point of Operation guards, safety light curtains, mechanical guards, and Two hand controls

In addition to local laws and codes, you are responsible for the safety recommendations detailed in all applicable codes and standards including:

- OSHA Regulations
- ANSI Standards
- NFPA
- CSA

IMPORTANT Rockwell Automation reserves the right to make revisions to these installation instructions and disclaims liability for all incidental and consequential damages related to the furnishing, performance and use of this material.

Area Access Control Safety Light Curtain Installation Instructions

Table of Contents

Introduction	3
System Configuration	3
Description of Function	3
Possible Applications	3
Possible Areas of Application	3
Application Conditions	3
Mechanical Arrangement	4
U.S. Safety Distance Formulas	4
OSHA Safety Distance Calculation formula	4
The ANSI Safety Distance Formula	4
Safety Distance to Point of Operation	5
Mechanical Mounting	6
Multiple Safeguarding	6
Mutual Interference	7
Corner Mirrors	8
Mounting	8
Mounting Requirements	8
Detecting Reflections	8
Electrical Connection	11
General Introduction	11
AAC Terminal Connections	12
Typical Wiring Diagram	13
Typical Wiring Diagram	14
Typical Wiring Diagram	15
Alignment	16
Alignment of the AAC	16
Alignment of AAC with Laser Alignment Aid	16
Checking Alignment	16
LED Indicators	17
Diagnostic Elements	17
Troubleshooting	18
Specifications	19
Dimensions	19
Accessories	20
Accessories Dimensions	21

Agency Approvals

EU Europe

EC Prototype test conducted by

BG - Berufsgenossenschaft
(Trade Association)

Fachausschuß Eisen und Metall III
(Technical Committee for Iron and Metall III)
Graf-Recke-Str. 69
D-40239 Dusseldorf



ATTENTION!

Failure to observe may result in dangerous operation

Throughout this manual we use the labels **ATTENTION** and **IMPORTANT** to alert you to the following:

ATTENTION: Identifies information about practices of circumstances that can lead to personal injury or death, property damage, or economic loss

ATTENTION helps you

- Identify a hazard
- Avoid a hazard
- Recognize the consequences

IMPORTANT: Identifies information that is especially important for successful application and understanding of the product.

All specifications subject to change

IMPORTANT: Save these instructions for use at a future time.

Generally recognized technical regulations and quality assurance system ISO 9000 are carefully applied during the development and production of Rockwell Automation products.

This technical description must be observed when installing and commissioning the AAC. Inspection and commissioning must be carried out by a specialist, if this is specified in the directives and guidelines.

Conditions required for proper use of the AAC Safety Single-Beam Light Curtain

The AAC safety single beams are intended to provide area access control or perimeter safeguarding of personnel for a variety of machinery and work cell applications.

Please make sure that you read and understand these following requirements before locating and installing the AAC Safety Single Beam.

The installation of the AAC Safety Single Beam must comply with all applicable federal, state and local rules, regulations, and codes.

AAC Safety Single Beam must be properly installed by qualified personnel.

AAC Safety Single Beams are presence devices and will not protect personnel from heat, chemicals or flying parts. They are intended to signal a stop of hazardous machine motion when the sensing field is broken.

AAC Safety Single Beams can only be used on machinery that can be stopped anywhere in the machinery's stroke or cycle.

AAC Safety Single Beam should never be used on full revolution clutched machinery.

The effectiveness of the AAC safety single beam depends upon the integrity of the machine control circuit. The machinery that the AAC safety single beam presence sensing device is installed on, should have control circuitry that is fail safe in design.

All stopping mechanisms for the machinery should be inspected regularly to ensure proper operation. The protected machinery must have a consistent reliable and repeatable stopping time.

It is the responsibility of the employer to properly install, operate and maintain the product as well as the machinery on which the AAC safety single beam presence sensing device is installed.



ATTENTION! Failure to read and follow these instructions can lead to misapplication or misuse of the AAC Safety Single Beam, resulting in personal injury and damage to equipment.

Area Access Control Safety Light Curtain Installation Instructions

Introduction

The AAC photoelectric safety switch is a single-beam, noncontact presence sensing safety device. It consists of a AAC light sender and a AAC light receiver. The light beam from the emitting to the receiving unit provides access protection for hazardous areas.

The safety device is designed for industrial applications. Its features include:

- Long scan range
- Easy installation
- Solid construction
- Heated front screen, i.e. it can be used even in unfavorable ambient conditions

The AAC complies with IEC 61496 parts 1 and 2, safety requirements for a type 4 safety device.

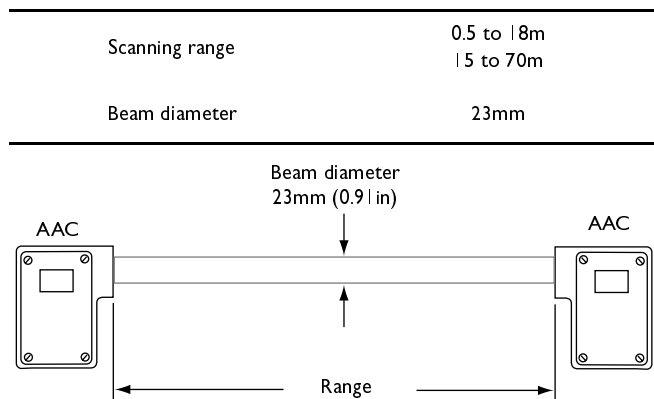

Figure 1 System construction of the AAC photoelectric safety switch

System Configuration

The AAC consists of:

- AAC sender unit, long or short range
- AAC receiver unit, long or short range.

A complete break in the light beam between the sender and receiver units triggers a signal which can be used to immediately stop hazardous motion.

The AAC serves as a presence-sensing safety device for perimeter guarding to protect personnel in potentially hazardous areas such as:

- Robotic work cells
- Machining centers
- Palletizers
- Plastics machinery
- Stackers
- Settling machinery in the stoneworking industry

Description of Function

The AACs are mounted separately in die-cast housings. Each has its own power supply (Figure 2). The AAC transmitter contains a clock generator and the sender diode. This diode emits infrared pulses at the clock rate set by the generator. These pulses are evaluated by the AAC receiver unit. If the light path is interrupted, it sends a stop command to the machine control.

The AAC receiver contains the output relays A and B, which are energized if the light path is interrupted. If the light path or the connection between terminals 10 and 11 on the AAC is interrupted (testing), both relays are released.



ATTENTION! The AAC must not be used as a hand or finger guard.

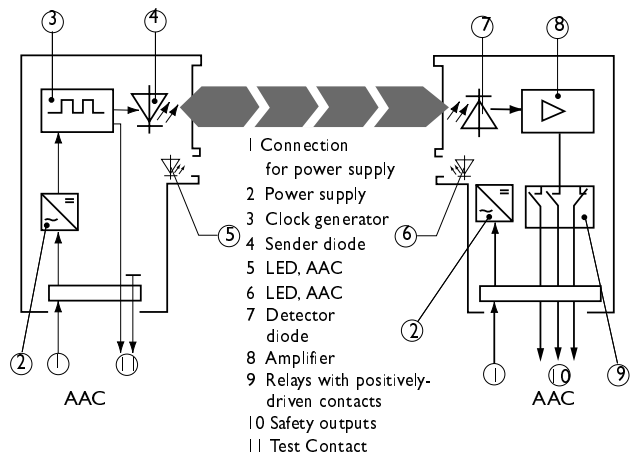

Figure 2 Principle of function of the AAC, AC version

Possible Applications

Possible Areas of Application

The AAC provides access protection for hazardous areas (Figure 3).

Application Conditions

A sensed intrusion can only be detected when the light beam diameter of 23mm (0.91 in) is fully covered.

The protective function of the AAC is ensured when the conditions set out in the warning box on this page are met.

Area Access Control Safety Light Curtain Installation Instructions

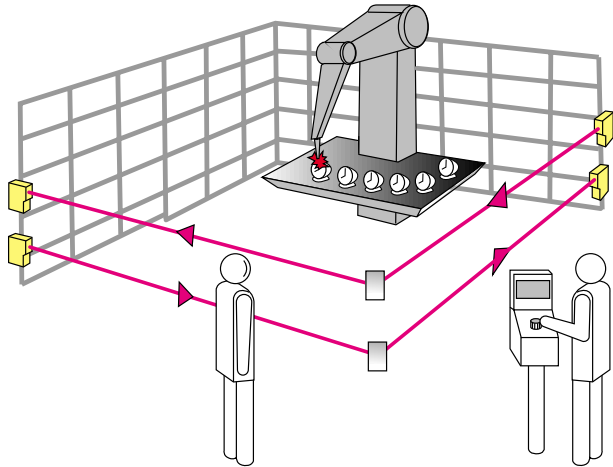

Figure 3 The AAC provides access protection for hazardous areas



ATTENTION! The power-driven machinery must be controlled by electrical means.

The AAC must be positioned so that entry into the hazardous area is only possible by breaking the light beam.

The command unit must be positioned so that it cannot be activated from within the hazardous area.

The operator of the command unit (e.g. restart button) must have a clear view of the hazardous area.

Mechanical Arrangement

U.S. Safety Distance Formulas

The AAC Safety Single Beam must be mounted at a sufficient distance from the pinch point or point of operation hazard to ensure that the machine stops before a person's finger, hand, arm(s), or body reaches the hazard. This distance, referred to as the safety distance, must be properly calculated prior to determining the safety light curtain protective height and mounting the light curtains on the machine. Failure to properly calculate this safety distance may result in operator injury.

Note: Regardless of the calculated safety distance, AAC Safety Single Beams should never be mounted closer than 6 inches from the point of operation or pinch point hazard.

In the United States there are two formulas that are used to properly calculate the safety distance. The first, the OSHA formula, is the minimum requirement for the calculation of the safety distance. The second formula, the one recommended by Rockwell Automation, is the ANSI formula, which incorporates additional factors to be considered when calculating the safety distance.

OSHA Safety Distance Calculation formula

The OSHA safety distance formula as specified in CFR Subpart O 1910.217 is as follows:

$$D_s = 63 \times T_s$$

Where:

D_s Safety Distance

63 Is the OSHA recommended hand speed constant in inches per second

T_s Is the total stop time of all devices in the safety circuit, measured in seconds. This value must include all components involved in stopping the hazardous motion of the machinery. For a mechanical power press it is the stopping time measured at approximately the 90° position of the crankshaft rotation.

Note: The T_s number must include the response times of *all* devices, including the response time of the safety light curtain, the safety light curtain controller (if used), the machine's control circuit and any other devices that react to stop the hazardous motion of the machinery. Not including the response time of a device or devices in the stop time calculation will result in insufficient safety distance for the application. This may result in operator injury.

The ANSI Safety Distance Formula

The ANSI safety distance formula, which is the Rockwell Automation recommended formula, is as follows:

$$D_s = K \times (T_s + T_c + T_r + T_{bm}) + D_{pf}$$

Where:

D_s Minimum safety distance between the safe guarding device and the nearest point of operation hazard, in inches.

K Hand speed constant in inches per second. The ANSI standard value is 63 inches per second when the operator begins reaching toward the point of operation hazard from rest. NOTE: ANSI B11.19 1990 E4.2.3.3.5 states "The value of the hand speed constant, K, has been determined by various studies and although these studies indicate speeds of 63 inches/second to over 100 inches/second, they are not conclusive determinations. The employer should consider all factors, including the physical ability of the operator, when determining the value of K to be used."

T_s Stop time of the machine tool measured at the final control element.

T_c Response time of the control system

Area Access Control Safety Light Curtain Installation Instructions

Note: NOTE: T_S and T_C are usually measured by a stop time measuring device.

T_r Response time of the presence sensing device (safety light curtain) and its interface, if any. This value is generally stated by the device manufacturer or it can be measured by the user.

T_{bm} Additional time allowed for the brake monitor to compensate for variations in normal stopping time.

D_{pf} Depth penetration factor: It is an added distance to allow for how far into the protective field an object, such as a finger or hand, can travel before being detected. D_{pf} is related to the safety light curtain's object sensitivity. Object sensitivity is the smallest diameter object which will always be detected anywhere in the sensing field.

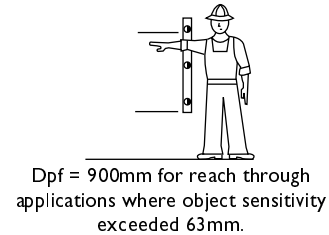
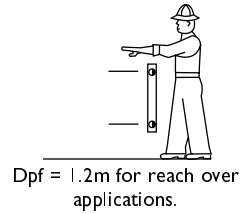

Safety Distance to Point of Operation

The safety device requires a minimum distance between the sensor and hazardous area of operation. This ensures that hazardous area of operation can be reached only after the hazardous motion has been stopped (Figure 4). The safety distance (according to EN 775, 999 and 294) depends on the following:

- Machine stop time
- Response time to the safety device including its interface
- Resolution of the safety device
- Hand speed

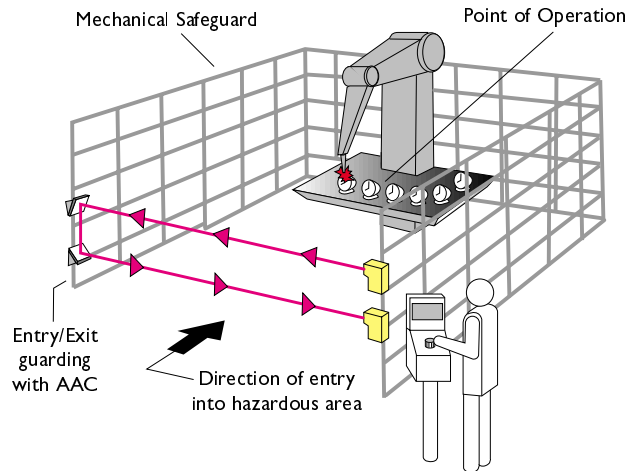

Figure 4 Safety distance to the light beam



ATTENTION! The AAC must be mounted so that if the beam is broken during hazardous movement of the machinery, the point of operation unless power-driven machinery is no longer in a hazardous state.

For this purpose, a safety distance must be maintained between the light beam and the nearest boundary of the point of operation. This safety distance is determined according to EN 999, and applicable ANSI standards

People within the hazardous area, but outside the light beam, are not detected. You must, therefore, ensure that any hazardous state can only be initiated when there is no one in the hazardous area.

Mechanical Mounting

The AAC can be mounted using the pre-tapped holes located on the bottom or on the lower front face of the units. This can be accomplished by using two screws through a hard mount or by using the mounting brackets shown in (Figure 5). This style of mounting bracket allows the devices to be mounted in almost any operating position while at the same time easing the alignment process.

However, each unit should be mounted such that the axis of the light beam emitted by the AAC always matches the axis of the AAC receiver.

Affix the mounting brackets so that all fixing screws are easily accessible for alignment purposes. Figure 5 shows examples. The devices should be attached such that the opposing device can be aligned in the alignment sight.

If, for reasons of space, the devices need to be arranged as shown in Figures 5 a and b, hexagon screws must be used.

Area Access Control Safety Light Curtain Installation Instructions

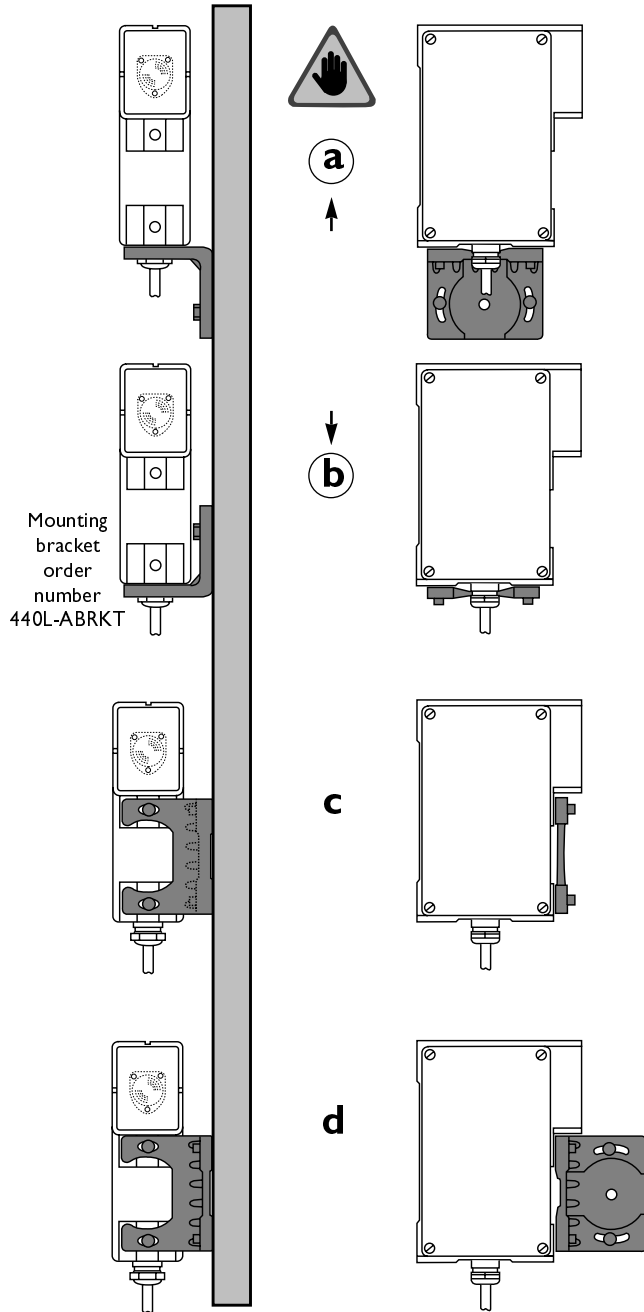

Figure 5 Mounting options using a mounting bracket

Multiple Safeguarding

When using two AAC pairs in a protective system, the possibility of mutual interference must be excluded. Since the light beam of the AAC diverges, the cross-section of the beam increases as the distance between the AAC Transmitter and the AAC receiver grows. The following conditions must, therefore, be met when arranging the two AACs.

Mutual Interference

The light beam of the AAC transmitter must only be received by the corresponding AAC receiver. To prevent mutual interference between several AAC installations arranged adjacent to or above each other, the specified beam diameters must be taken into account when mounting the devices (Figure 6).

IMPORTANT

There are two versions of the AAC. One for operating ranges 0.5 to 18m and one for 15 to 70m. The 15 to 70m AAC must not be used for operating ranges below 15m. The operating range is given on the rating plate.

Area Access Control Safety Light Curtain Installation Instructions

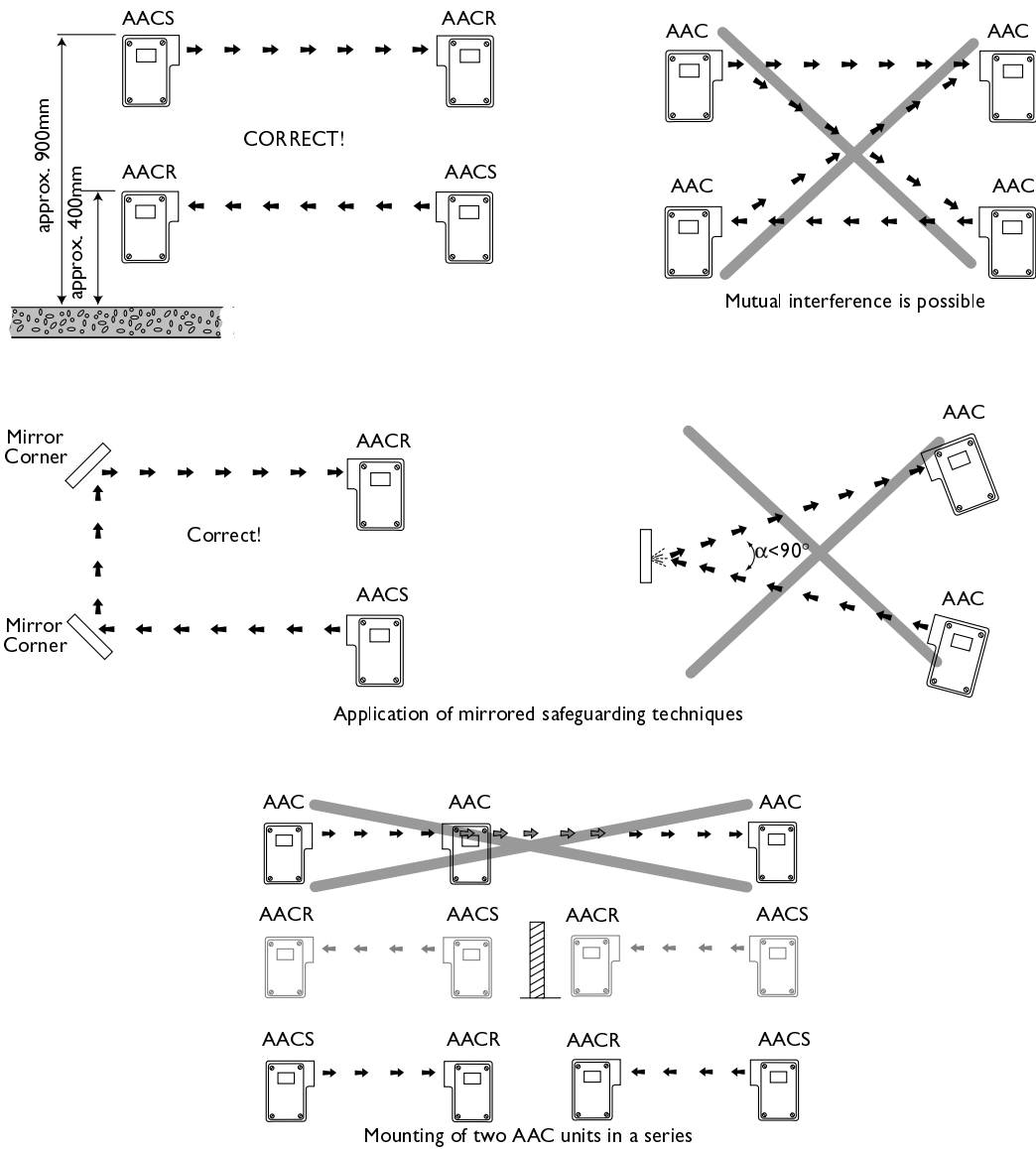

Figure 6 Correct and incorrect procedures for AAC set-up

Area Access Control Safety Light Curtain Installation Instructions

Corner Mirrors

The AAC can provide multisided, two-beam access protection when used in conjunction with corner mirrors, as shown in Figures 7 and 8).

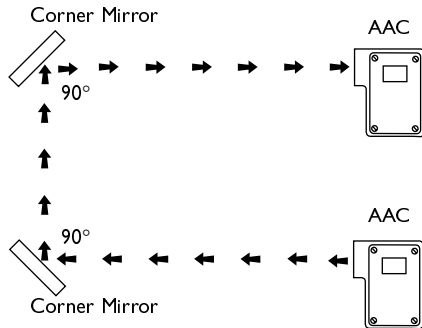

Figure 7 Two-beam protection with an AAC system

IMPORTANT The use of corner mirrors reduces the scanning range of the AAC system as cited in the table below.

Number of Mirrors	Reduced Scanning Range	Reduced Scanning Range
	0.5 to 18m AAC	15 to 70m AAC
1	17m	67m
2	15.5m	61m
3	13m	51m
4	11m	42m

IMPORTANT The use of more than two mirrors requires a very accurate alignment. A laser alignment unit (440L-ALAT) with the adaptor (440L-ALBRK I) is recommended for 3 sided guarding.

Mounting

Mounting Requirements

The devices should be mounted and connected in accordance with the onsite application conditions and connections, taking into account the conditions listed in the box below.



ATTENTION! The scanning range is based on the width of the area being protected. Bypassing or encircling the light beam must be prevented by suitable (mechanical) means. Where one or more AAC units are used, the

height and number of beams must comply with the applicable regulations. There must be no reflective surfaces in the emitting or receiving beam path. The minimum safety distance must be maintained.

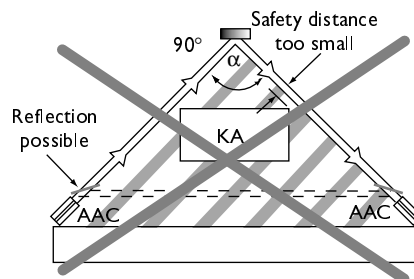
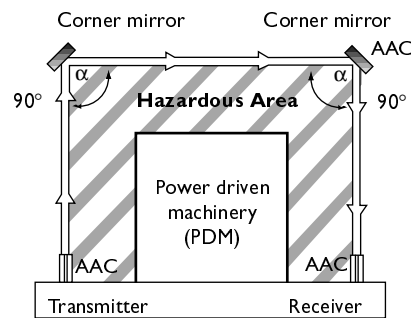
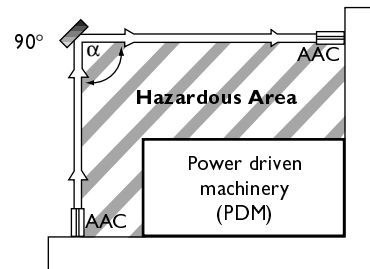

Figure 8 Multi-sided protection of hazardous areas

Area Access Control Safety Light Curtain Installation Instructions

Detecting Reflections

The light beam must not be unintentionally reflected back to the receiver by reflective surfaces. Figure 11 shows the divergence distance, a , as a function of the scanning distance, SR. Reflections can be detected as detailed in Figures 9 and 10.



ATTENTION! Cover the light beam between the sender and receiver fully with an obstacle (100mm x 100mm) and slowly move the obstacle from the sender unit to the receiver unit.

While this is happening the green LED on the AAC must not light up. If it lights up even briefly during this check, reflection is occurring

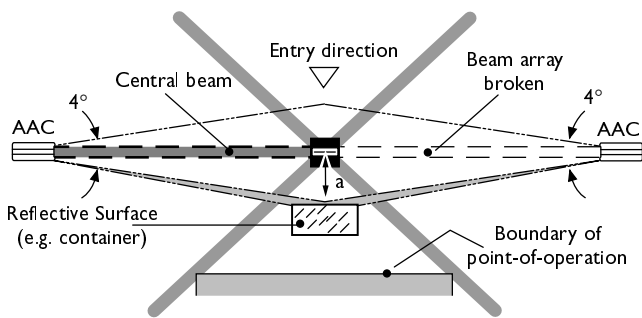

Figure 9 Incorrect mounting: reflective object in divergent light beam. No detection of the obstacle due to reflection. No protection to personnel

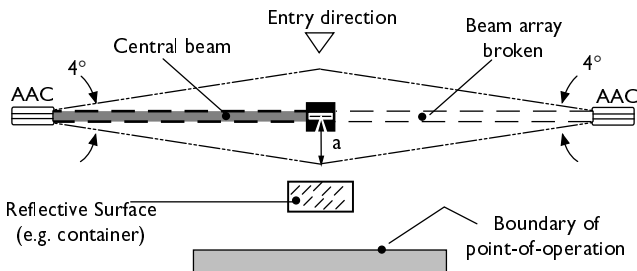

Figure 10 Correct installation, correctly aligned: reflective object outside divergent light beam. Personnel protected

Area Access Control Safety Light Curtain Installation Instructions

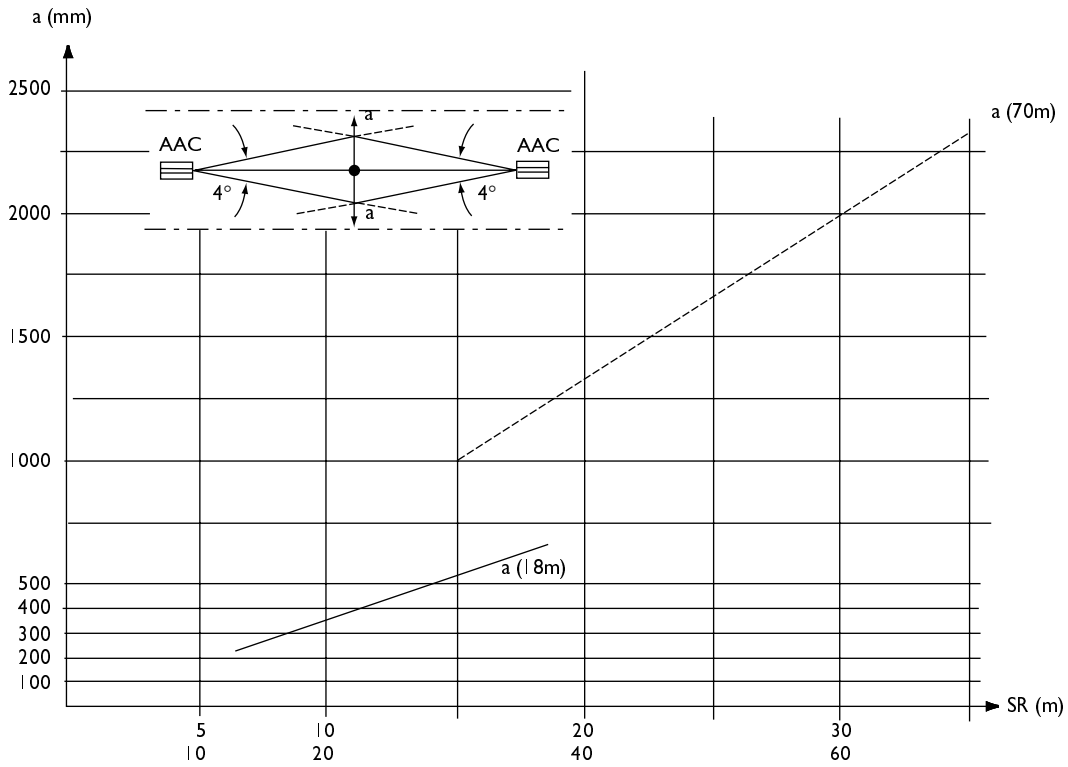

Figure 11 Distance as a function of scanning range SR

Area Access Control Safety Light Curtain Installation Instructions

Electrical Connection

General Introduction

Depending on model, the AAC presence sensing safety device is available with a supply voltage of:

- 24V DC
- 115V AC

Before connection, check that the supply voltage and frequency are consistent with the specifications.

The cable is fed through the PG connector and connected inside the device per terminal connections shown in Figure 12. The wiring diagram is also depicted on the housing cover of the respective device.

The enclosure rating for the devices can only be guaranteed when the cable is properly clamped in the PG connector and the housing seals fit properly. Where long leads are used, the cable cross-sections should be chosen to ensure the devices are always supplied with the required voltage (see Specifications).

The two system components must be of the same voltage version and the same scanning ranges. Conductors up to 1.5mm² (AWG 16) can be connected to the screwless terminals. Stripping length: 11 mm (7/16in).



ATTENTION! Arc-suppression elements are essential across inductive loads! Arc-suppression elements must be connected in parallel with the load as shown in Figure 13. Connection in parallel with the output contacts is not permitted.

Diodes must not be used as arc-suppression elements.



ATTENTION! The electrical connection of the AAC must only be made or changed with the power disconnected.

Unscrew the housing cover to connect the AAC with a PG connector:

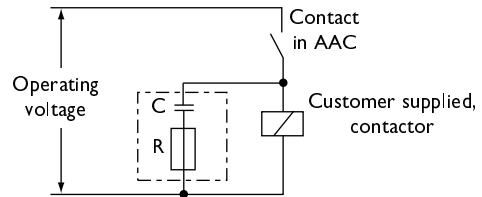

Operating voltage	R	C
115	220 Ω	0.22 μF
24	100 Ω	2.2 μF

Figure 13 Guide values for arc-suppression elements.

Area Access Control Safety Light Curtain Installation Instructions

AAC Terminal Connections

24V DC

Transmitter

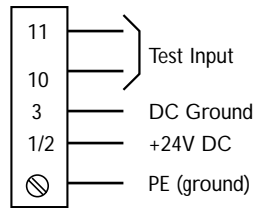

Receiver

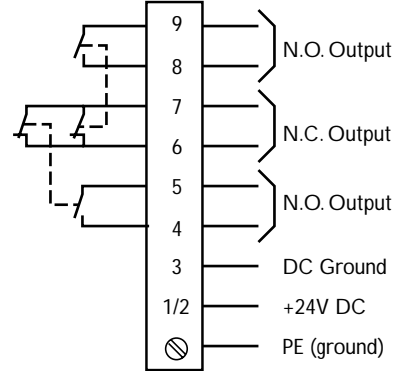

115V AC

Transmitter

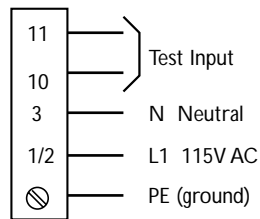

Receiver

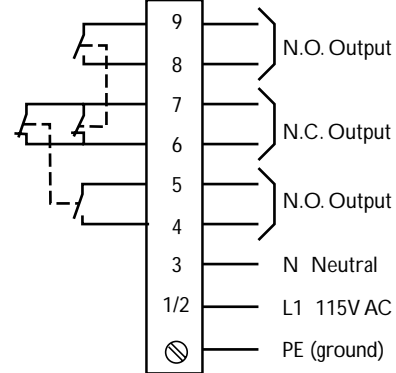
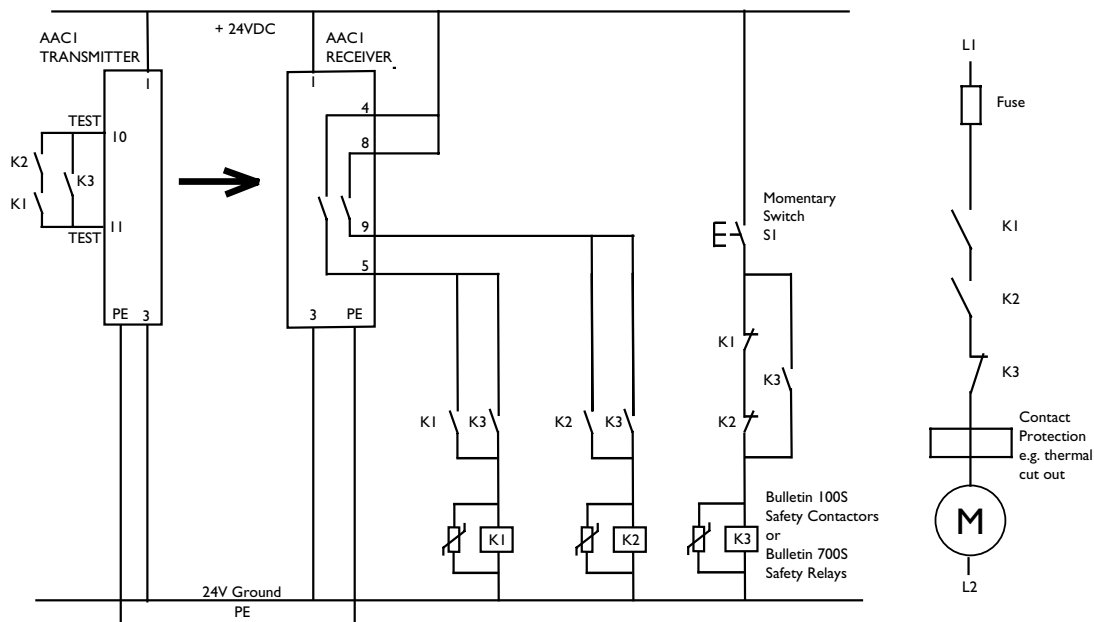

Figure 12 AAC Terminal Connections

Area Access Control Safety Light Curtain Installation Instructions

Typical Wiring Diagram



Circuit Status

The light beam is off. The motor is off.

Operating Principle

Pressing S1 energizes K3, which closes the test inputs to the AAC1 sender. The sender turns on its emitter LED.

The AAC2 receiver accepts the emitted beam from the sender and closes its N.O. contacts at terminals 4/5 and 8/9.

Contactors K1 and K2 are energized through the K3 contacts and then are self-latched by their own respective N.O. contacts. At the AAC1 sender, the K1 and K2 N.O. contacts maintain the emitter in an ON state.

When S1 is released, K3 drops out.

The motor is now running.

Breaking the light beam will cause the motor to turn OFF.

Fault Detection

A malfunction of one of the contactors K1 or K2 does not lead to the loss of the safety function.

If K3 is continuously activated due to a malfunction, the output circuit remains in an OFF state.

A short across either output of the AAC2 receiver will cause either K1 or K2 to remain energized and will prevent future energization of K3.

If Switch S1 becomes shorted, K3 will always remain energized which will turn the load OFF.

Comments

Be sure to avoid reflections that may cause the AAC receiver to stay energized while personnel are walking through the beam.

Figure 14 Dual Light Curtain Area Access Control with Bulletin 100S safety contactors or 700S safety relays

Area Access Control Safety Light Curtain Installation Instructions

Typical Wiring Diagram

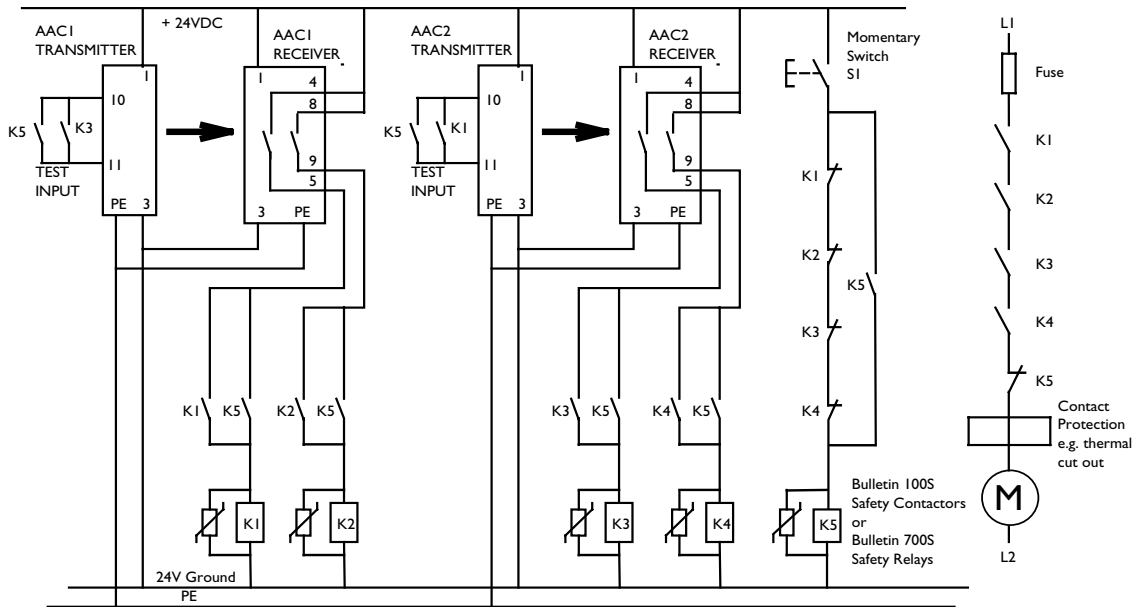

Circuit Status

The light beams are off. The motor is off.

Operating Principle

Pressing S1 energizes K5, which closes the test inputs to the AAC1 and AAC2 transmitters. The transmitters turn on their emitter LEDs.

The AAC1 and AAC2 receivers accept the emitted beam from their respective transmitters and close their N.O. contacts at terminals 4/5 and 8/9.

Contactors K1, K2, K3 and K4 are energized through the K5 contacts and then are self-latched by their own respective N.O. contacts. At the AAC1 and AAC2 transmitters, the K1 and K3 N.O. contacts maintain the emitter in an ON state.

When S1 is released, K5 drops out.

The motor is now running.

Breaking the beam at either AAC1 or AAC2 will cause the motor to turn OFF.

Fault Detection

A malfunction of one of the contactors K1, K2, K3 or K4 does not lead to the loss of the safety function.

If K5 is continuously activated due to a malfunction, the output circuit remains in an OFF state.

A short across one of the AAC receiver outputs will cause either K1, K2, K3 or K4 to remain energized and will prevent future energization of K5.

If Switch S1 becomes shorted, K5 will always remain energized which will turn the load OFF.

Comments

Be sure to avoid mutual interference and reflective objects when installing Area Access Control light curtains, as the receivers may remain energized as personnel are walking through the beams.

Figure 15. Dual Light Curtain Area Access Control with Bulletin 100S safety contactors or 700S safety relays

Area Access Control Safety Light Curtain Installation Instructions

Typical Wiring Diagram

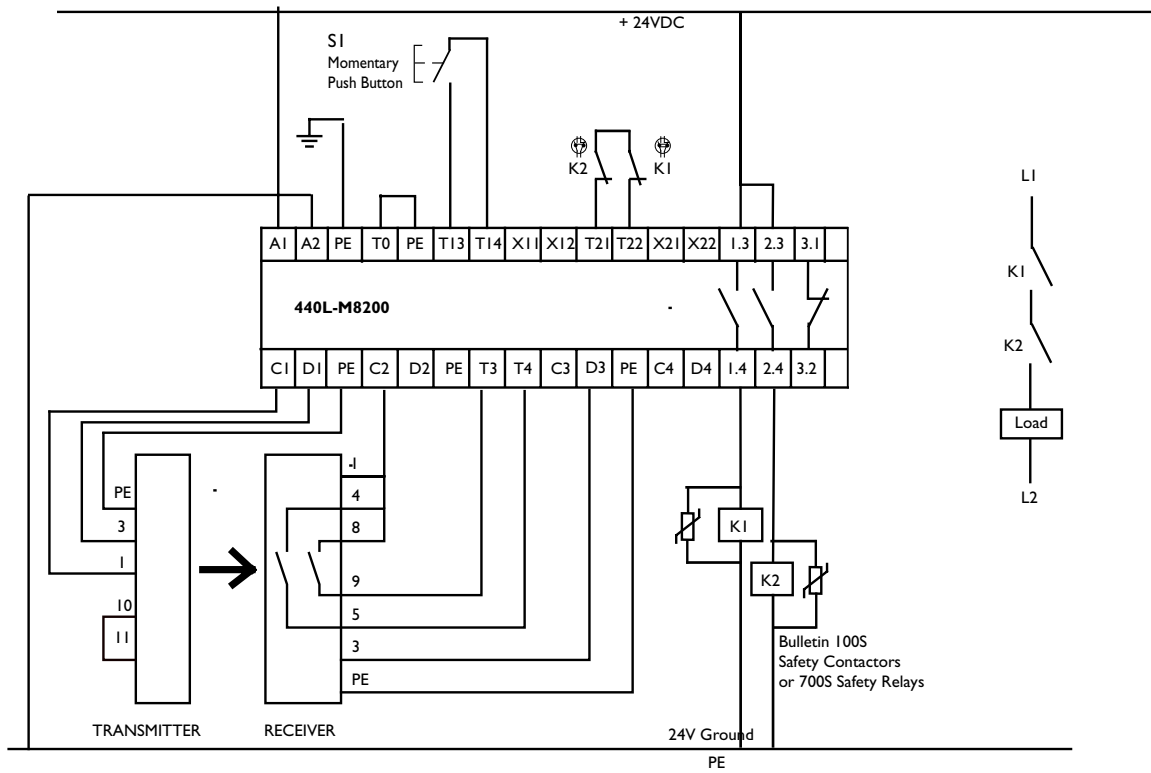

Circuit status

Circuit shown with no objects in either sensing field and the output contactors are de-energized.

Operating principle

Pressing and releasing switch S1 will energize the output contactors K1 and K2.

Breaking the light beam will de-energize the output contactors K1 and K2 and turn the load off.

Fault detection

A single fault will not cause a loss of safety function.

If either contactor K1 or K2 sticks ON - the load will denegize due to the other contactor operating properly.

A short on S1 will be detected by the 440L-M8200.

Comments

Be sure to check that the contactor coil power requirements are within the specifications of the 440L-M8200.

Figure 16. Area Access Control Light Curtains with 440L-M8200 controller and Bulletin 100S (or 700S) contactors - Dual Channel.

Area Access Control Safety Light Curtain Installation Instructions

Alignment

Alignment of the AAC

After checking the electrical connections, loosen the fixing screws on the AAC and align the devices to each other roughly using the alignment sight. For further alignment keep pressing button S or jumper terminals I0 and I1 on the AAC and switch on the devices. When this is done the LED on the AAC (yellow LED) lights up (Figure 17).

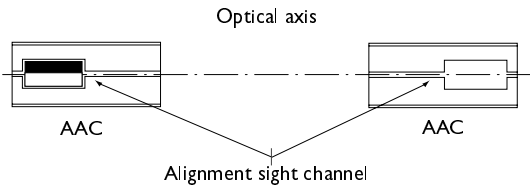

Figure 17 Alignment with the aid of the alignment sight

Align the devices to each other so that the green and yellow LEDs on the AAC light up.

For optimum alignment, ascertain the limits of the emitting and receiving ranges by swiveling the AAC horizontally and vertically one after the other. Just before the limit of the optical range, the yellow LED on the AAC begins to flash. Beyond the optical range the red LED on the AAC lights up.

Then secure the AAC respectively in the middle of the resulting ranges. The yellow LED on the AAC must be permanently lit.

Alignment of AAC with Laser Alignment Aid

For precise alignment of the AAC the laser alignment aid is available. P/N 440L-ALAT

The alignment aid is clamped in front of the AAC respectively on a bracket (Figure 18), which is mounted underneath the optic and held in place by two screws.

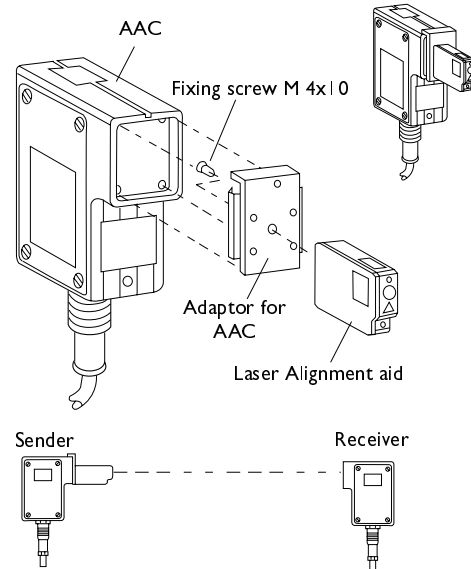

Figure 18 Laser alignment aid and AAC

The laser alignment aid emits a visible laser beam which exactly marks the optical axes of AAC if they are correctly mounted.

Checking Alignment

Incorrect alignment may mean that an obstacle is not detected or that operational safety is not attained.

The functional safety of the photoelectric safety switch is checked by breaking the light beam continually and along its entire length, from just in front of the AAC back to the AAC (Surface area 100mm x 100mm). While this check is being performed, the red LED on the AAC must remain continuously lit. If it does not, investigate the diversion of the light beam between the AAC Transmitter and the AAC receiver; reflection may be occurring.

A function check of this kind must be carried out:

- daily, prior to start of production,
- after any change in the AAC configuration,
- after any servicing or maintenance work on the protective system

Area Access Control Safety Light Curtain Installation Instructions

LED Indicators

Diagnostic Elements

The LEDs on the AAC shown in Figure 19 indicate the operating states detailed in the Table 1.

Cleaning!

The front screens of the AAC transmitter and AAC receiver must be cleaned at regular intervals, determined by site conditions. The screens must be cleaned only with a clean, soft cloth.

Use plastic cleaner as the cleaning agent.

IMPORTANT Certain solvents and cleaning agents can damage the AAC lens.

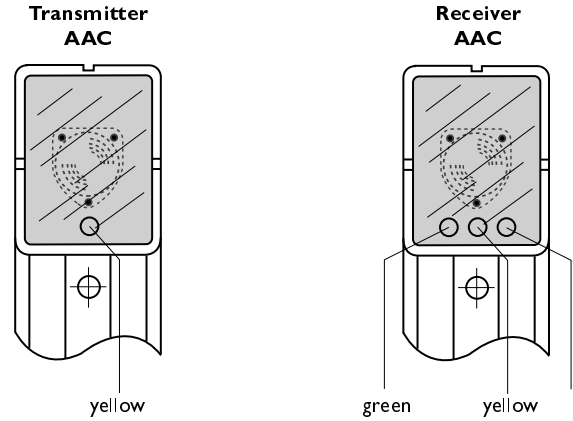

Figure 19 LEDs of the AAC

Table 1 LED Indicator Lights

	Sender unit AAC	Receiver unit AAC		
	Yellow	Green	Yellow	Red
Continuously lit	Operating voltage applied (test contact closed)	Light beam of sender unit reaching receiver	Sufficient light received	Light beam broken or test contact open on AAC or system not aligned
Flashing	--	--	Insufficient light received, unit still functioning	--
Off	No operating voltage applied or test active (test contact open)	No operating voltage applied, light beam broken, test performed	Light beam broken, test performed, no operating voltage applied	No operating voltage applied, no light received from sender

Area Access Control Safety Light Curtain Installation Instructions

Troubleshooting

Simple malfunctions can be rectified by referring to Table 2. Before opening up the units, clean the housing thoroughly to prevent dirt from getting inside the unit.



ATTENTION! Do not touch any electrical connections when the unit is open and switched on.

Table 2 Troubleshooting Guide

Fault	Cause	Action
LED on AAC not lit	No power supply	Check voltage
	Break between terminals I 0 & I 1 (test contact)	Check test contact
LED on AAC transmitter lit, none of the 3 LEDs on the AAC receiver are lit	No power supply on AAC	Check voltage on AAC
	Break at relay contact; relay defective	Replace unit
The red LED on the AAC is permanently lit (no light being received)	Unit out of alignment	Re-align AAC units
	Front screen dirty	Clean front screens of AAC
	Test input (sender) interrupted	Check testing
	Receiver AAC defective Sender AAC not emitting	Replace unit On AAC briefly switch power off and on again (min 1 s)
	Sender AAC defective	Replace unit
The yellow LED on the AAC flashes (insufficient light being received)	Units or corner mirrors out of alignment	Adjust units or corner mirrors to optimum alignment
	Front screen of AAC or corner mirror dirty	Clean front screen or corner mirror
The yellow & red LEDs on the AAC receiver are permanently lit	Electronics activated	On AAC briefly switch power off/on again (minimum is 1 sec)
	Interference of another emitter element	AAC receiver must only respond to the corresponding ACC transmitter
	Electronic card defective	Replace unit

Area Access Control Safety Light Curtain Installation Instructions

Specifications

Dimensions	
Protective field range	0.5 to 18m or 15 to 70m
Number of beams	1
Light beam diameter	23mm
Sender/Receiver Unit	
Supply voltage	24V DC $\pm 20\%$ 230V AC $\pm 10\%/-15\%$  115V AC $\pm 10\%/-15\%$
Ripple	Max. 5% of Uv
Frequency	8 to 62Hz with AC version
Input, sender	Test contact
Test time	Max. 150ms
Min. Opening Time of NC	
Contact for test	75ms
Power Consumption	
Voltage version	24V 115V 230V
Sender unit	5W 8W 8W
Receiver unit	8W 11W 11W
Synchronization	Optical
Outputs	Relays
Switching current (max./min.)	2A/0.02A
Switching voltage (max./min.)	250V AC/24V DC
Response time	$\leq 22\text{ms}$
Connection cable	PG connector: IP67
Front screen heating	Standard
Operating Data	
Protection Class	I
Enclosure Rating	IP67 (PG connector)
Safety category	Satisfies type 4 requirements
Requirements	IEC 61496 Part I/Part II
Ambient operating temperature	-25°C to 55°C
Storage temperature	-25°C to 70°C
Air humidity	15% to 95%
Vibration	5g, 10 to 55Hz to IEC 68-2-6
Impact Resistance	10g, 16ms to IEC 68-2-29
Weight	Sender unit: approx. 0.9 to 1.3kg Receiver unit: approx. 1 to 1.4kg

Dimensions

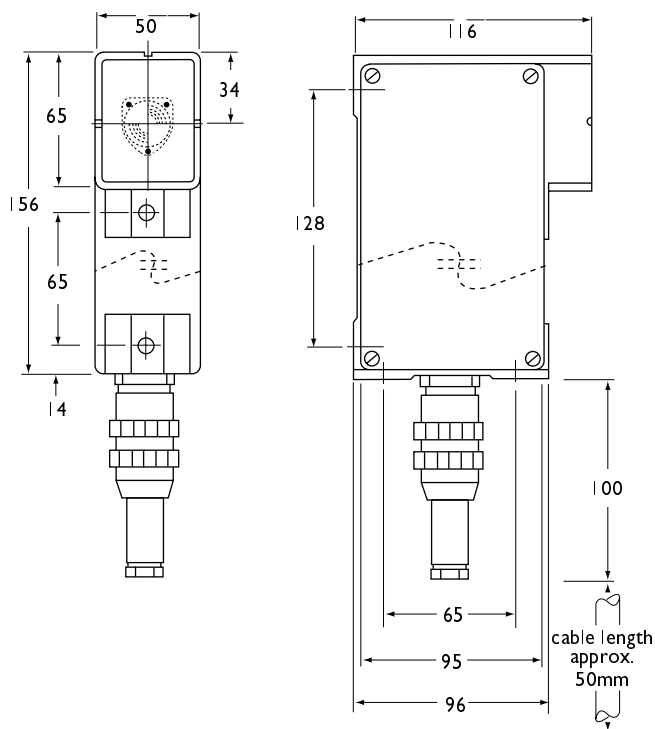

Terminal Block Cable Gland

 Contact factory.

Area Access Control Safety Light Curtain Installation Instructions

Accessories Dimensions

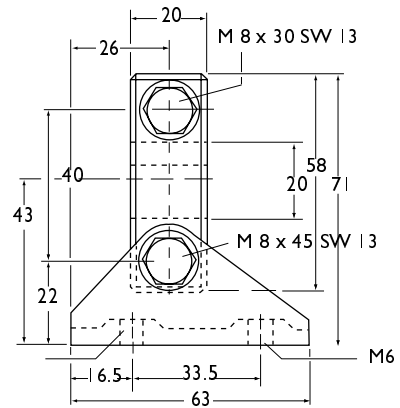
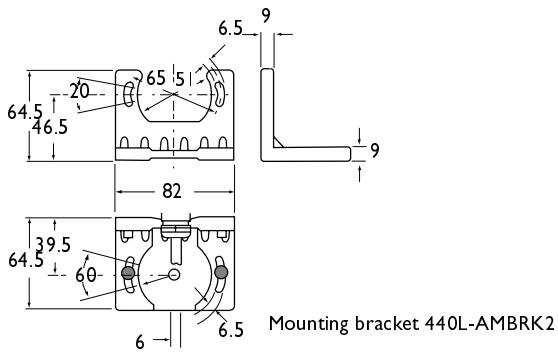

Bracket for corner mirror 440L-AMBRK1

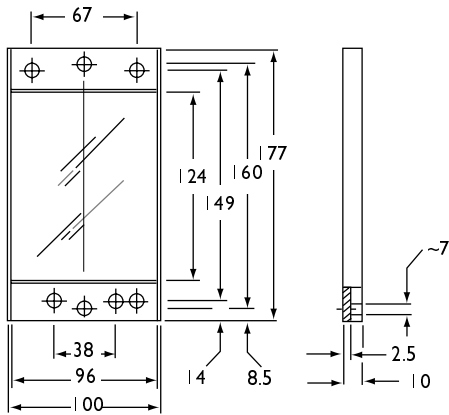

Corner mirror

Order no.
440L - AMIRR1

Dimensions in mm

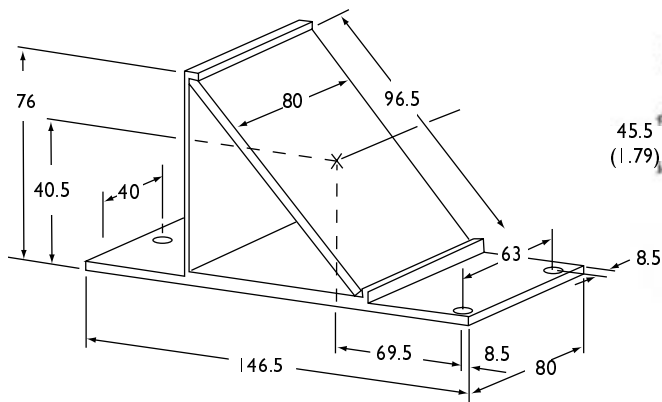
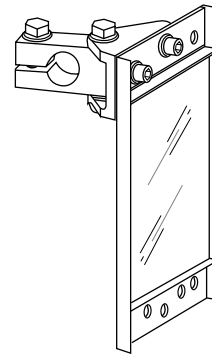

P/N: 440L-AMIRR3

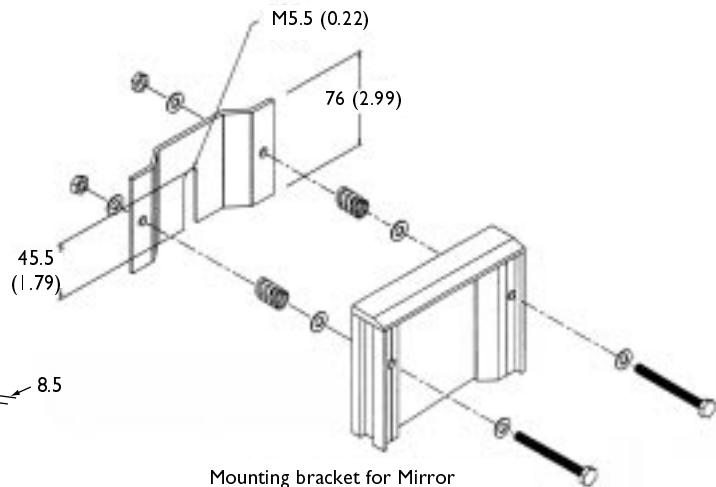

Mounting bracket for Mirror
bracket part number includes
one bracket and hardware.
440L-AMBRK3



Please contact us for Technical Assistance:

In the U.S.: 1-800-666-0001

Outside U.S.: 001-978-441-9500

On line: <http://www.ab.com/safety>

Reach us now at www.rockwellautomation.com

Wherever you need us, Rockwell Automation brings together leading brands in industrial automation including Allen-Bradley controls, Reliance Electric power transmission products, Dodge mechanical power transmission components, and Rockwell Software. Rockwell Automation's unique, flexible approach to helping customers achieve a competitive advantage is supported by thousands of authorized partners, distributors and system integrators around the world.

Americas Headquarters, 1201 South Second Street, Milwaukee, WI 53204, USA, Tel: (1) 414 382-2000, Fax: (1) 414 382-4444
European Headquarters SA/NV, avenue Herrmann Debroux, 46, 1160 Brussels, Belgium, Tel: (32) 2 663 06 00, Fax: (32) 2 663 06 40
Asia Pacific Headquarters, 27/F Citicorp Centre, 18 Whitfield Road, Causeway Bay, Hong Kong, Tel: (852) 2887 4788, Fax: (852) 2508 1846



Rockwell Automation