



Allen-Bradley

Guardmaster®

GuardEdge™

**PRESSURE SENSITIVE
SAFETY EDGE SYSTEM**

INSTALLATION & USER MANUAL

READ THIS MANUAL IN FULL BEFORE INSTALLATION

After installation this manual should be retained in a safe and accessible place



Allen-Bradley

Guardmaster®

Drawing No: 31611/0

6.2.4 Repair

Prior to working on a GuardEdge system or machine control system, isolate the power source to the machine and GuardEdge system. Observe electrical safety precautions.

User repairs are limited to replacement with new GuardEdge system parts. In the event of any problems, the units should be returned to the supplier.

Any repairs to the connecting wires should be made using heat shrink butt splice connectors.

After replacing any parts the inspection and test shown at 6.2.2 & 6.2.3, must be carried out with special attention given to those parts replaced.

**TAMPERING WITH COMPONENT PARTS WILL INVALIDATE WARRANTY.
WARRANTY INVALID IF QUALITY SEAL IS BROKEN ON THE DIN RAIL (440F-C251D) CONTROL UNIT**

WARNING

After maintenance or repair operations it is important that all fastenings, cable protection etc, are correctly refitted. Failure to do this or the use of non approved parts may result in the GuardEdge system failing to achieve its specified performance.

3.0 INSTALLATION OF THE GUARDEDGE SYSTEM

ONLY USE 440F-A0020 CYANOACRYLATE.

The cyanoacrylate adhesive ensuring a lasting sealing and high protection to IP65.

3.1 INSTALLATION OF "C" RAIL

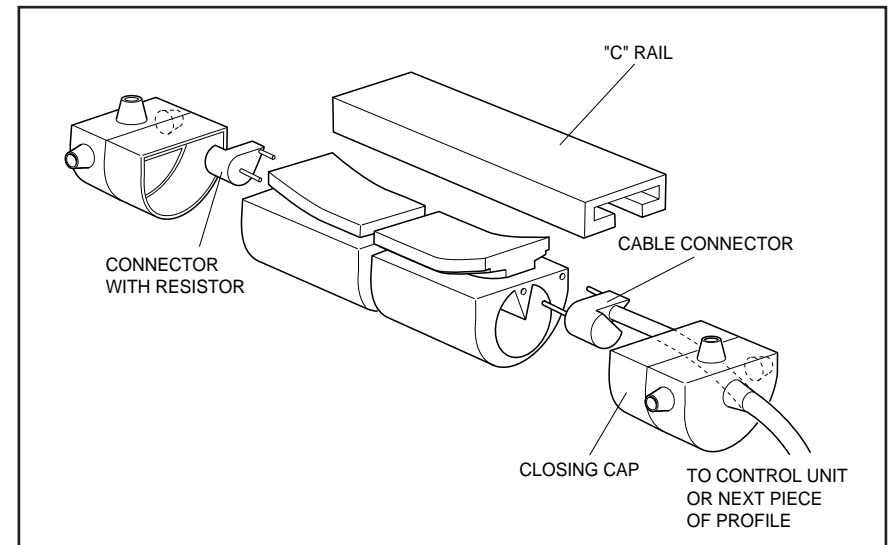

3.1.1 MOUNTING THE "C" RAIL

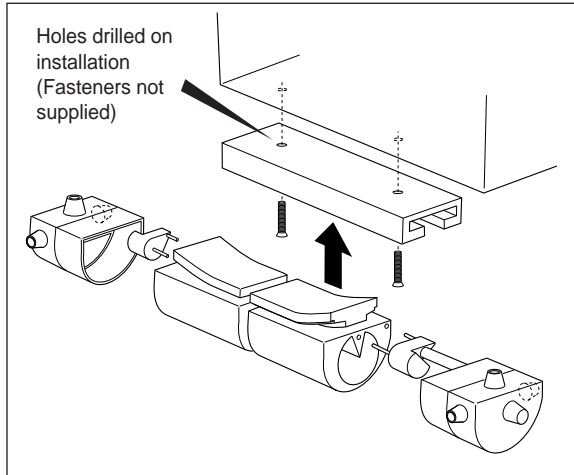

3.2 ASSEMBLY & INSTALLATION OF THE GUARDEDGE PROFILE

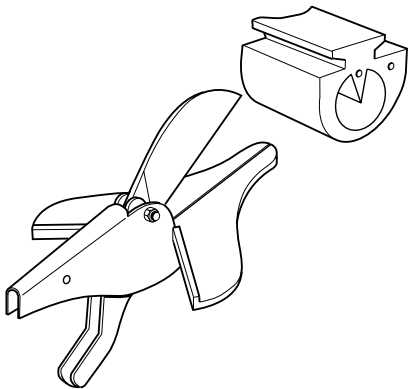

- 3.2.1** Cut the GuardEdge Profile to length.
Profiles without coasting chamber should be cut with rubber shears.
Profiles with coasting chamber should be cut with a fine tooth saw.

6.2.1 Profile Cleaning

The Profiles should be kept clean of deposits such as swarf and other materials to prevent damage or dead-zones. It is permissible to use warm water and a mild detergent to clean the surface area.
DO NOT USE SOLVENTS.

6.2.2 Routine maintenance inspection and test - (*recommended weekly or after repair*)
Stop the machine, clean the Profile(s) and allow to dry off. Inspect the surface of the Profile for damage. Any damage that punctures the profile could let material or liquid in. It must be dealt with immediately. Check that all end caps, corners and joints are secure and free from damage. Damaged parts must be replaced immediately.

Test the Profile operation. Two people may be required, one to press the Profile and one to observe the operation of the control unit. On systems using Manual reset mode, the reset button must be continuously pressed. Check that the RUN "Green" LED is illuminated when the profile is not pressed and that the STOP "Red" LED is illuminated when it is. Start the machine, press the Profile and check that the machine stops immediately.

If these checks reveal any problems, do not allow use of the machine until they are rectified. Record all inspections and tests in a written log.

6.2.3 Thorough examination and test - (*twice yearly or after repair*)

To be undertaken by a person competent in electrical and mechanical engineering.

- Carry out tests at 6.2.2
- Isolate the power source to the machine and GuardEdge system. Observe electrical safety precautions.
- Inspect the Profile and components thoroughly for mechanical damage.
- Disconnect the wires to the Profile at terminals Z1-Z2.
- Connect the wires from the Profile to the input of an ohmmeter. One person should now press the Profile with one hand at every point on the strip. The resistance should measure $6K\Omega \pm 10\%$ when the profile is not pressed and no greater than $1K$ when it is.

If these checks reveal any problems, do not allow the use of the machine until they are rectified. Record the inspection and test in a written log.

6.0 MAINTENANCE AND SERVICE

6.1 FAULT FINDING GUIDE

Symptom	Probable Cause	Check
"Yellow" LED Illuminates.	Open circuit in profile or connecting wiring.	Z1-Z2 Terminals are secure. Cable for breaks Profile for damage.
No LED's illuminate even if Profile is pressed.	Supply failure.	Voltage selector switch is set correctly. Supply fuse. Supply voltage is present.
No LED's illuminate unless Profile is pressed and then the stop "Red" LED illuminates.	Failure to reset.	If using contactor monitoring, check each contactor is functioning correctly. MC-MC terminals are secure. Link is in place or Reset button functions correctly.
Unit appears to work correctly but there is no output.	Blown fuse. Damaged or incorrect wiring.	Output fuses. All wiring for damage.
	Fault on GuardEdge causing the Outputs to fail safe	Movement on any internal relays. REPLACE CONTROLLER.
Machine does not stop if Profile pressed. Run "Green" LED goes off.	Incorrect external connections	All wiring to contactors for mistakes.
Machine does not stop if Profile pressed. Run "Green" LED stays on.		DO NOT ALLOW THE USE OF THE MACHINE REPLACE CONTROLLER.

6.2 MAINTENANCE

This section should be read in full before any maintenance work is attempted.

Attention is drawn to regulations for planned preventative maintenance under E.U. Directive 89/655/EEC (Implemented in Great Britain as the Provision and Use of Work Equipment Regulations 1992).

During maintenance operations, disconnect the machine's prime mover before working on the GuardEdge system. Observe electrical safety precautions.

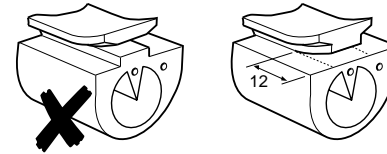

3.2.2 When using the closing cap 440F-A1302 with sealing lip, the profile base has to be cut back to a length of 12mm. The cut must be made carefully to ensure that the profile base is completely trimmed off, leaving a flush surface.

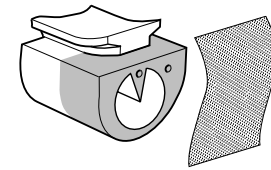

3.2.3 The shaded areas must be roughened with emery paper

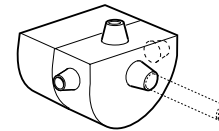

3.2.4 The closing caps are moulded with 4 grommets, each with a rubber plug. When fitting a resistor, leave the plugs intact. When making a cable connection, select the required cable exit and remove the plug from the grommet with a hole punch.

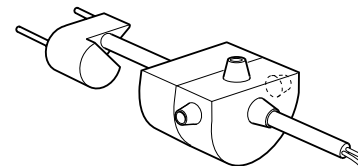

3.2.5 Pull the connecting cable through the hole.

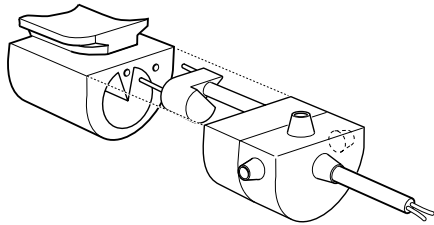

3.2.6 Prick each of the copper wires with one of the needles. Press the needle contacts of the connector in the direction shown: (wedge outwards), straight into the copper wires.

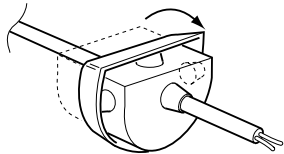

3.2.7 CAUTION
The narrow side (wedge) of the connector must show outwards.

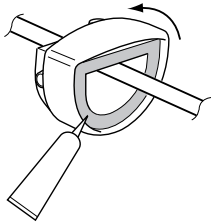

3.2.8 Fold back the sealing lip of the cap;
a) Apply adhesive to shaded area of closing cap as illustrated then affix to edge of profile, applying pressure for 10 seconds to ensure adhesion.
b) Apply adhesive to remainder of shaded area and allow sealing lip to make contact with profile.

IMPORTANT: Spread the adhesive evenly over the shaded area! Do not allow adhesive to enter inside the profile.

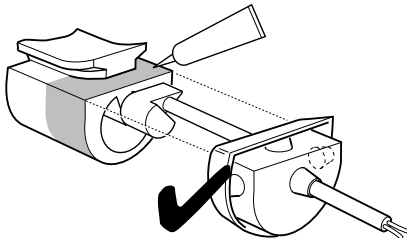

5.3 APPLICATIONS

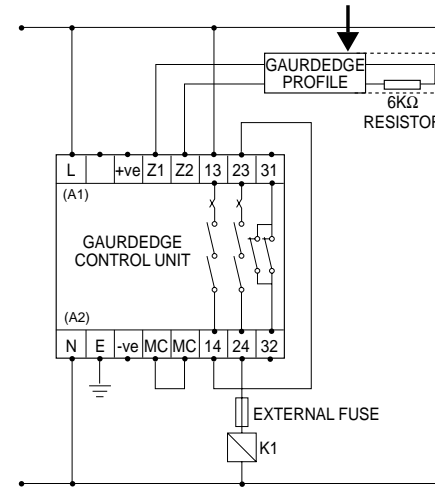

110/230V AC Application with 1 contactor.
(Shown with profile pressed).

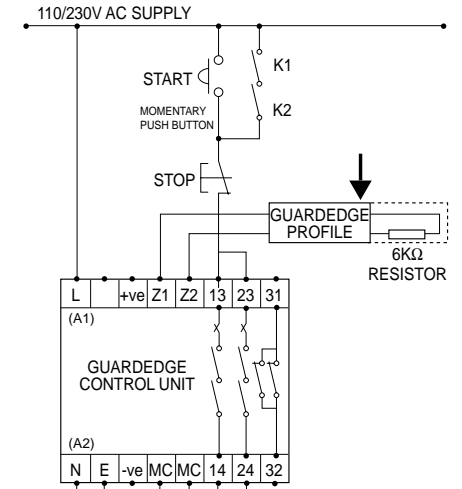

110/230V AC Application with 2 contactors, contactor monitoring and START/STOP circuit.
(Shown with profile pressed)

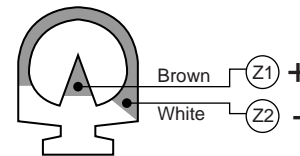

5.2 AUTOMATIC RESET MODE

- 1) Turn the power on
 - a) Run "Green" LED illuminates.
 - b) Safety contacts close.
 - c) Auxiliary contacts open .
 - d) Contactors energise.

- 2) Press the Profile
 - a) Run "Green" LED extinguishes.
 - b) Stop "Red" LED illuminates.
 - c) Safety contacts open.
 - d) Auxiliary contacts close.
 - e) Contactors de-energise.

- 3) Release the Profile
 - a) System has returned to step 1a.

Comparative properties

	Profiles		Profiles	
	440F-E0110N 440F-E1610N	440F-E0110S 440F-E1610S	440F-E0110R 440F-E0804S 440F-E0210S	440F-E0510S 440F-E0310S
Tensile strength (reinforced) MPa	26		20	
Resilience (20°C)	F		G	
Low temperature flexibility	F		G	
Resistance to sunlight	G		G	
Resistance to heat ageing	G		G	
Resistance to oxidation	F		G	
Resistance to ozone	F		G	
Resistance to H ₂ O	G		G	
Resistance to dilute acids	F		G	
Resistance to concentrated acids	F		G	
Resistance to oils & greases	G		P	

Key:- G = Good F = Fair P = Poor

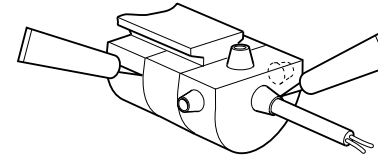

3.2.9 To ensure complete seal apply more adhesive on the GuardEdge Profile around grommet/cable exit and sealing lip of the closing cap.

440F-A0061S

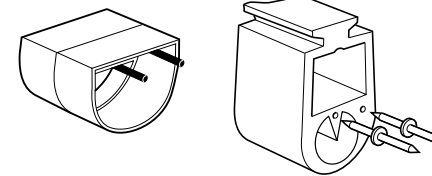

3.2.10 Axial profile connector 440F-A0061S is used for extensions and repairs (see steps 1, 2, 3, 6 and 7) for the 440F-E0110 series of profiles only. For other types, use straight pin connectors.

3.3 CONTROL UNIT

3.3.1 TECHNICAL SPECIFICATION

	440F-C251P Surface mount	440F-C251D DIN rail
Conformity:	prEN 1760-2, EN 954-1: CATEGORY 3	
Power Supply - user select:	110/230V AC (50-60Hz) and 24V AC/DC +10% -15%	
System response time:	13mS	
Environmental protection:	IP65.	Enclosure IP40 DIN0470 Terminals IP20 DIN0470
Max. GuardEdge profile voltage:	12V DC (open circuit).	
Nominal operating voltage:	4V (run condition).	
Max. output fuse:	2A quick acting	5A quick acting
Impulse withstand voltage:	2500V.	
Over voltage:	Category 2	
Contamination level:	III	
Min. switched current/voltage:	10mA/10V	
Power consumption:	<6 VA	

	440F-C251P Surface mount	440F-C251D DIN rail
Relay outputs:	2 x independant volt free N/O safety contacts 1 x volt free N/C auxiliary contact NOTE: Auxiliary should not be used for safety	
Utilisation category:	AC - 15; 2A / 250V DC DC - 13; 2A / 30V DC	
Safety inputs:	GuardEdge profile (open resistance 6K Ω)	
Indication LED 1:	Green: Run.	
LED 2:	Yellow: Open.	
LED 3:	Red: Stop.	
Internal controls:	AC voltage selector	
Internal fuses:	2A safety fuses replaceable (2 off) 500mA supply fuse replaceable (1 off)	500mA supply fuse replaceable (1 off)
Max. output fuse:	N/A	4A on AC / 2A on DC
Ambient temp. range - control unit	-10°C to + 55°C.	
Ambient temp. range - profile	-5°C to +55°C excluding)110N & 01610N (0°C to 55°C)	
Humidity:	Up to 90% RH at + 55°C.	
Vibration:	Tested in accordance with IEC 68-2-6, frequency range 10 - 55Hz, displacement 0.15mm 10 cycles per axis, sweep rate, 1 octave per minute	
MC-MC contactor monitor loop:	N/C (normally closed) contactor loop	
Max. conductor size:	1 x 1 mm ² stranded with sleeves stripped 5mm, 1 x 1.5mm ² solid conductor.	1x2.5 mm ² stranded with sleeves stripped 8mm, 1 x 4 mm ² solid conductor
Terminals:	Minus terminal screws M2 spring action.	Plus-minus terminal screws M3.5 with self lifting connection, washer terminal boards separately removable.
Installation group:	C in accordance with VDE 0110.	
Material:	Polycarbonate	
Fixing details:	4 x M4 holes	35 mm DIN Rail
Housing:	D=75mm, H=130mm, W=130mm	D=120mm, H=73mm, W=45.5mm, 16 way
Weight:	650g	450g
Miscellaneous:	The GuardEdge Profile must be terminated with a 6K Ω resistor.	

5.0 COMMISSIONING & USE SEQUENCE OF OPERATION

When the unit is installed, check the following sequence of operation.

5.1 Manual reset mode.

- 1) Turn the Power on
 - a) No LED's illuminate.
- 2) Press the reset switch
 - a) Run "Green" LED illuminates.
 - b) Safety contacts close.
 - c) Auxiliary contacts open.
 - d) Contactors energise.
- 3) Press the Profile
 - a) Run "Green" LED extinguishes.
 - b) Stop "Red" LED illuminates.
 - c) Safety contacts open.
 - d) Auxiliary contacts close.
 - e) Contactors de-energise.
- 4) Release the Profile
 - a) Stop "Red" LED extinguishes.
 - b) System has returned to step 1a.
- 5) If Profile is pressed before reset
 - a) Stop "Red" LED will illuminate each time the Profile is pressed but the safety contacts will not energise.

4.6 Reset terminal MC-MC

These terminals are used for a number of different functions (surface mount supplied jumpered, DIN rail supplied without jumper). Without the jumper the terminals can be connected to positively guided normally closed auxiliary contacts on the machine contactors to provide monitoring of the contactors in dual channel control systems. If one contactor fails to isolate the power at de-energisation of its control coil, the GuardEdge system will not allow the other contactor to be energised until the fault has been rectified. Fit a jumper between these terminals on the DIN rail unit if this function is not required. This terminal is also used for auto/manual reset. If the MC-MC terminal is left jumpered or connected up to the contactors normally closed contact only, the unit is in automatic reset mode. In automatic reset mode the output is achieved solely by removal of the actuating force. The output is also achieved at power up of the actuator (when there is no actuation force present). If a spontaneous restart may generate a risk, based on the result of a risk assessment to EN1050, then this mode must not be used. See EN 60204 Pt.1 and EN954 Pt.1. For manual reset mode a normally open spring return (not latching) push button must be connected across the MC-MC terminals or in series with the contactors normally closed. When the actuating force is removed, the unit will not operate until the button is pressed. The button will also have to be pressed after power up of the control unit.

4.7 Profile connection to control units

These terminals are used to connect the Profile to the:-
 Z1 = Brown (inner conductor).
 Z2 = White (outer conductor).
 Refer to 5.3 APPLICATIONS.

NOTE: Profile must be terminated with a 6K Ω Resistor (yellow) for series connection. When two profiles are connected directly to Z1 and Z2 (parallel) then each profile should be terminated with a 15K resistor (blue).

Connection in Parallel & Series

CONNECTING IN SERIES

If more than one profile is to be used they are normally connected in series as shown.

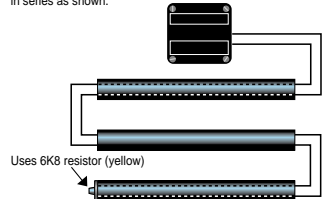

ALTERNATIVE CONNECTION METHOD

CONNECTING IN PARALLEL

A maximum of two profiles can be connected in parallel to assist in ease of wiring in certain applications.

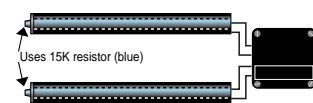

	440F-E0110N	440F-E0110S	440F-E0310S	440F-E1610N	440F-E1610S
--	-------------	-------------	-------------	-------------	-------------

actuating distance:	6.4mm	6.6mm	8.0mm	7.8mm	9.4mm
response distance:	1.2mm	1.9mm	27.2mm	8.4mm	5.0mm

- max. speed: 100 mm/s
- suitable for the detection of fingers

The control unit must not be mounted inside the hazard zone. Access to the control unit is required for manual reset or for routine indicator observation so it must be able to be seen operating. The control unit can be mounted on either side of power doors, as long as the only hazard is the actual doors. In all other cases the control unit can be mounted anywhere convenient outside the hazard zone, taking into account the access requirements for test and maintenance.

3.3.2 MOUNTING

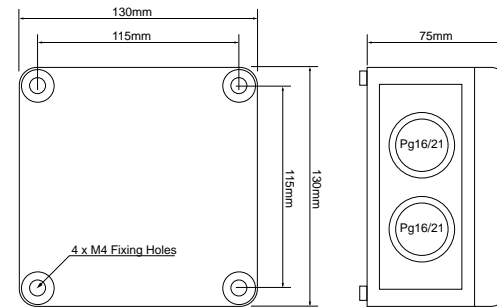

440F-C251P (Surface Mounted)

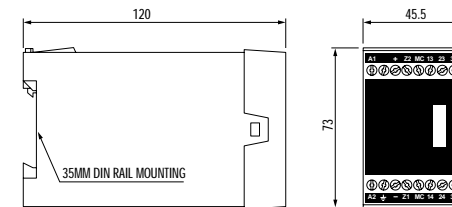

440F-C251D (Din Rail Mounted)

4.0 ELECTRICAL CONNECTIONS - GuardEdge control unit

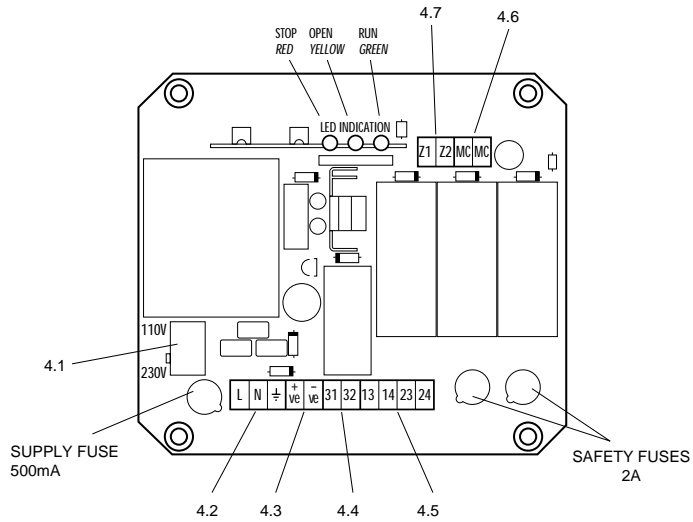

440F-C251P (Surface Mounted)

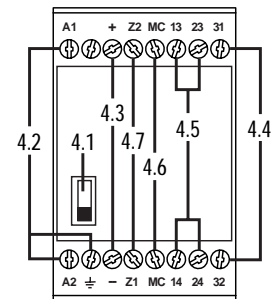
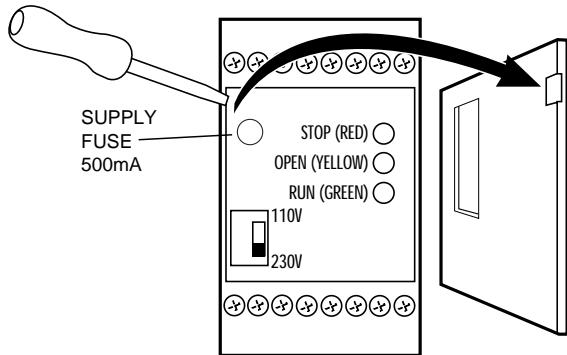

440F-C251D (Din Rail Mounted)

CONTROL UNIT INSTALLATION AND WIRING - (Follow steps 4.1 to 4.7 for correct installation)

IMPORTANT: Wiring must be in accordance with the National Electric Code and applicable local codes and ordinances

4.1 Mains selector switch

If using a 110V AC or a 230V AC supply, the voltage selector switch should be set as appropriate before turning the power on. The unit is set to 230V AC when manufactured.

4.2 Mains input terminal LN $\frac{\perp}{\perp}$ (A1, A2, $\frac{\perp}{\perp}$)

If a 110V AC or 230V AC supply is used it should be wired, together with a protective earth (ground) to the terminals shown. The size of the protective earth (ground) wire should be at least equal to that of the supply wire. Also check (4.1). If these terminals are used, ignore (4.3).

4.3 24V AC/DC input terminal +ve and -ve

If a 24V AC/DC supply is being used, the supply should be connected to these terminals, ensuring that the correct polarity is observed. Do not make any connections to the terminals of (4.2). Where a 24V AC or DC supply is used, it must be isolated from the mains supply in accordance with international electrical safety practice (IEC 364-4-41). One pole should be earthed. For 24V DC the negative pole should be earthed (grounded). With 24V AC the earthed (grounded) pole of the power supply should be connected to the -ve terminal.

4.4 Aux Output terminal 31 and 32

This terminal provides an auxiliary normally closed contact (i.e. closed when the green "Run" light is off) which is suitable for indication or for alarm devices. As this is an auxiliary, it must not be connected to the safety circuit.

4.5 Safety Output terminal 13, 14, 23 and 24

These are volt free contacts for connection to the machine safety circuits i.e. they are connected in series with the machine contactor control circuit. (Max. rating 2A at 250V AC). Both of these safety circuits are internally fused but must also be externally protected with a 2A quick acting fuse. If one contactor is being used, terminals 13 and 24 are required and terminals 14 and 23 should be jumpered together. For 2 contactors with 2 independent control circuits (i.e. a dual channel system), use 13-14 for one contactor and 23-24 for the other. For 2 contactors, also see (5.3).